

BUILT-IN APPLIANCES



CANDY BUILT-IN APPLIANCES DIVISION

New Chester Rd - Bromborough - Wirral - CH62 3PE

Telephone: 0151-334 2781 - Fax: 0151-334 9056

Website: www.candy-domestic.co.uk

A division of the Hoover Candy Group

08/11



TECHNICAL SPECIFICATIONS / DUO AND TRIO RANGE

| Model | DUO AND TRIO | | | |
|-----------------------------|--------------------|--------------------------|----------------------------------|-----------|
| | DUO 609 | TRIO 9503 | DUO 609 | TRIO 9503 |
| Product description | Oven dishwasher | Oven, hob, dishwasher | Dishwasher | |
| Finish | X | X | Number of IEC place settings | 6 |
| Hob | | | Number of programmes | 6 |
| 4 gas burners | | - | Water consumption (litres - IEC) | 9 |
| Flame failure device | | - | Rapid programme (mins) | 32 |
| One touch ignition | | - | Anti-overflow device | • |
| Enamelled pan supports | | - | Energy efficiency class | A |
| 4 hi-light zones | | • | Wash efficiency class | A |
| Oven | | | Drying efficiency class | A |
| Multi-function oven | • | • | Dimensions | |
| Grill | • | • | Height (mm) with adjustable legs | 835-900 |
| Timer | - | End of cooking | Width (mm) | 596 |
| Number of glass door panels | 2 | 2 | Depth (mm) | 570 |
| Volume (litres) | 39 | 39 | | |
| Energy classification | A | A | | |



CANDY

TECHNICAL SPECIFICATIONS / WARMING DRAWER

| Model | WARMING DRAWER | | |
|------------------------------|----------------|--------------------|------|
| | CPWD 140X | | |
| Keep warm programme | • | Max capacity | 25kg |
| Pre-heating crockery | • | Max absorbed power | 620W |
| Temp adjustable from 30-80°C | • | Dimensions | |
| Anti-slip mat | • | Height (mm) | 140 |
| Illuminated on/off switch | • | Width (mm) | 597 |
| Telescopic pull-out drawer | • | Depth (mm) | 525 |

TECHNICAL SPECIFICATIONS / WINE COOLERS

| Model | WINE COOLERS | | | | Model | WINE COOLERS | | | |
|--------------------------------|--------------|------------|----------|---------|-----------------|--------------|------------|----------|----------|
| | CCVB 25T UK | CCVB 60 UK | CCVB 120 | CCVB110 | | CCVB 25T UK | CCVB 60 UK | CCVB 120 | CCVB 110 |
| Width | 15cm | 30cm | 60cm | 60cm | Front Vent | • | • | • | • |
| Total gross capacity | 20 | 57 | 120 | 110 | Adjustable feet | • | • | • | • |
| Bottle storage capacity | 7 | 12 | 35 | 24 | Height (mm) | 820-890 | 820-890 | 820-890 | 820-890 |
| LED display with light | • | • | • | • | Width | 150 | 295 | 597 | 597 |
| Adjustable temperature control | 8-22 | 4-18 | 4-18 | 4-18 | Depth | 553 | 553 | 550 | 550 |

Key: X - Stainless Steel NX - Black & Stainless Steel N - Black B - White GR - Grey GH - Charcoal



All Candy appliances come with a free five year's parts guarantee when you register your purchase. What's more the comprehensive Candy After Sales Service Promise covers every eventuality. So, in the unlikely event of a fault occurring there's no need to worry - we take care of everything.



Candy Advice Line
08444 995599

Republic of Ireland
Telephone: (00353) 818 200021



UNI EN ISO



Group activities including all factories and the organisation structure are ISO 9001 accredited. Candy's policy is one of continuous improvement, therefore we reserve the right to modify or alter specifications without prior notice. All products subject to availability.

■ THE CANDY PHILOSOPHY

A real understanding of consumer requirements is central to Candy's ongoing research and development programme. By anticipating changes in taste and lifestyle Candy has translated research results into unique appliance innovations, producing kitchen appliances that are efficient, technically advanced and beautifully styled. Developed for today's lifestyle these new appliances will co-ordinate perfectly with contemporary as well as the more traditional kitchen designs and all come with a guarantee of satisfaction from a company that has a reputation for taking care of its customers.

The Candy logo is rendered in a bold, blue, 3D-style font. The letters are thick and have a slight shadow, giving them a three-dimensional appearance. The 'C' is particularly large and curved, leading into the 'A', 'N', 'D', and 'Y' which are also thick and blocky.

CONTENTS

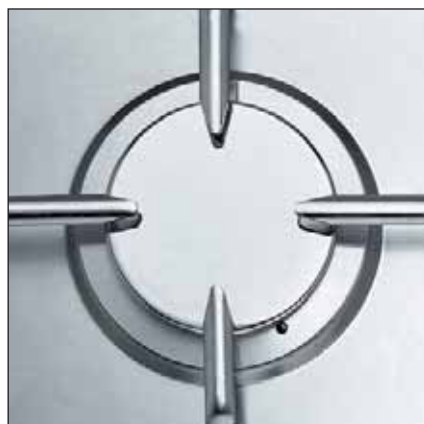

OVENS

| | |
|--------------------------|----|
| U•See ovens | 8 |
| Plan ovens | 10 |
| Gas Ovens | 10 |
| Classic Oven | 10 |
| Built-in warming drawer | 11 |
| Built-in Microwave ovens | 11 |
| Iron oven | 12 |
| Plan Light ovens | 14 |
| Plan Double ovens | 16 |
| Duo range | 18 |
| Trio range | 20 |

HOBBS

| | |
|-----------------------|----|
| Plan gas hobs | 24 |
| Iron gas hobs | 24 |
| Classic gas hob | 25 |
| Plan gas hob | 26 |
| Gas hobs | 27 |
| Electric hob | 27 |
| Hi-light Ceramic hobs | 28 |
| Induction hobs | 28 |
| Domino hob | 30 |

HOODS

| | |
|--------------------|----|
| Island hoods | 34 |
| Decor hoods | 34 |
| Plan decor hoods | 35 |
| Chimney hoods | 36 |
| Integrated hoods | 37 |
| Canopy hoods | 37 |
| Conventional hoods | 37 |



DISHWASHERS

| | |
|--------------------------------------|-----------|
| Fully integrated dishwashers | 40 |
| Semi Integrated Dishwasher | 41 |
| Fully integrated Slimline dishwasher | 41 |



LAUNDRY

| | |
|-----------------------------------|-----------|
| Fully integrated washer dryers | 42 |
| Fully integrated washing machines | 42 |



REFRIGERATION

| | |
|----------------------------------|-----------|
| Side by side fridge freezer | 46 |
| Fully integrated fridge freezers | 46 |
| Fully integrated refrigeration | 48 |
| Built-in wine coolers | 50 |



TECHNICAL SPECIFICATIONS

From page

51



OVENS

Candy's Plan range which includes single and double ovens combines the attraction of simple styling with the quality of a great brand. It's flat front styling, clean-cut lines and careful positioning of controls are in line with the latest trends in cooking design.

Energy Efficient

Candy Ovens offer outstanding performance as some are now rated A -20%.



NEW OVEN DOOR DESIGN

Candy single ovens have a new full glass oven door for easy cleaning and a larger glass window for improved visibility.



SAFETY SHELF SYSTEM

The oven walls feature specially designed grooves that allow the shelves to slide more easily. The grooves also prevent the shelves from being pulled out completely.



A CLASS CLEAN SYSTEM

The new A Class Enamel, smooth as glass, is completely water and dirt repellent. Its ultra smooth surface prevents dirt from adhering to the surface, and withstands corrosion from high sugar-content foodstuffs.



■ U·SEE OVENS

U·SEE

Candy's innovative U·see technology combines outstanding performance with exceptionally low energy consumption. Fourteen ultra white lights on the oven door perimeter illuminate the whole cavity, providing perfect visibility throughout the entire oven. Use ovens range from A-20 to A rated for energy efficiency and the LED lights use only 1kw of electricity compared to conventional oven lights that consume between 20wh -50wh.

U·SEE



FVH 929 XL MULTI-FUNCTION OVEN

11 functions including ucook > multi-function oven > variable grill > **14 U.see LED Lights** > touch display > push pull controls > defrost function > pizza function > conventional cooking > fan cooking > integral fan cooling system > A class enamel - easy to clean oven interior > double glazed door > telescopic shelves > 53 litre capacity > energy class A-20

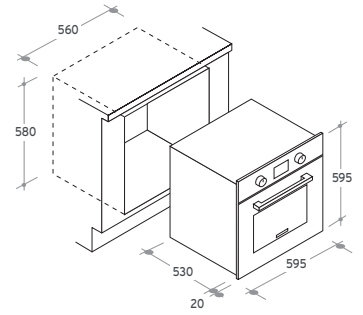

■ stainless steelFVH 929 XL



FVP 729 X MULTI-FUNCTION OVEN

8 functions including soft cook > multi-function oven > variable grill > **14 U.see LED Lights** > defrost function > conventional cooking > fan cooking > pizza function > A class enamel - easy to clean oven interior > safety shelf system > 2 shelves > 1 roasting tray / baking tray > double glazed door > 53 litre capacity > flat glass inner door > energy class A

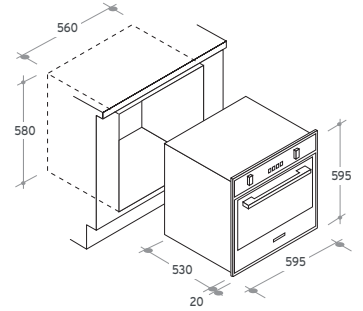

■ stainless steelFVP 729 X



FVP 702/1X MULTI-FUNCTION OVEN

8 functions including soft cook > multi-function oven > variable grill > **14 U.see LED Lights** > defrost function > conventional cooking > fan cooking > pizza function > A class enamel - easy to clean oven interior > safety shelf system > 2 shelves > 1 roasting tray / baking tray > double glazed door > 53 litre capacity > flat glass inner door > energy class A

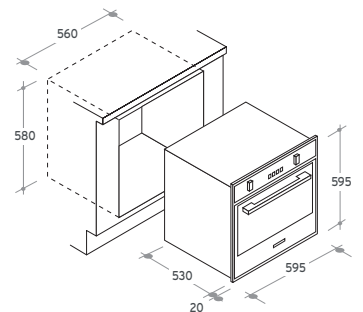

■ stainless steelFVP 702/1X

OVENS / PLAN RANGE



FFN 403 X FAN OVEN

fan cooking > grill > end of cooking timer > **integral fan cooling system** > oven light > A class enamel - easy to clean oven interior > safety shelf system > 2 shelves > 1 roasting tray/grill pan > double glazed door > 53 litre capacity > energy class A

■ stainless steelFFN 403 X

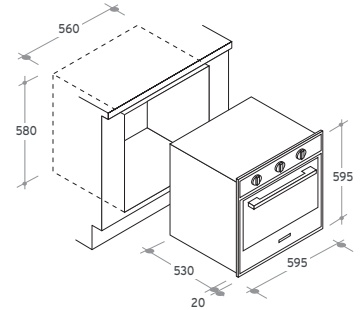

OVENS / GAS OVEN



OVG 505 GAS OVEN

Minute minder > traditional gas cooking > gas grill > fan cooled fascia and door > **electronic ignition for both oven and grill** > oven light > 2 shelves > 1 grill pan > double glazed door > 50 litre capacity

■ stainless steelOVG 505/2X
 ■ blackOVG 505/2N
 ■ whiteOVG 505/2W

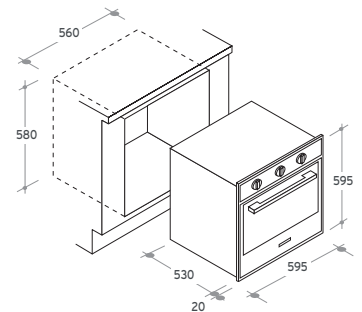

OVENS / CLASSIC OVEN



FCL 614/1GH MULTI-FUNCTION OVEN

8 functions > variable grill > defrost function > conventional cooking > fan cooking > analogue clock > A class enamel - easy to clean oven interior > 2 shelves > 1 roasting tray/baking tray > integral fan cooling system > oven light > 53 litre capacity > energy class A

■ charcoalFCL 614/1GH

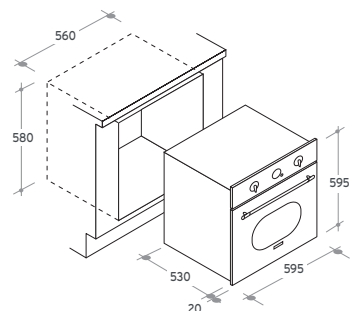

COMBINATION OVEN, MICROWAVE AND GRILL



MIC 440 TX COMBINATION OVEN, MICROWAVE AND GRILL

Electronic touch control > **LED Clock/Programmer**
 > **8 cooking combinations - conventional cooking, fan cooking, microwave cooking and grilling** > 13 automatic menus > 2 defrost functions > stainless steel cavity > 44 litre volume > 36cm diameter turntable > microwave power rating 900 W > grill power rating 1750 W > 5 power levels 150-900 W

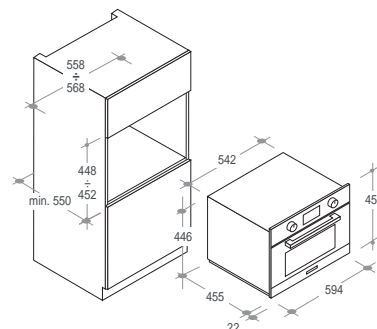

■ stainless steelMIC 440 TX

COMBINATION MICROWAVE OVEN AND GRILL



MIC 20 GDFX COMBINATION MICROWAVE OVEN AND GRILL

5 power levels > **3 cooking combinations** > microwave plus grill > microwave only > grill only > **electronic controls** > 8 automatic cooking functions > stainless steel interior > 24.5cm diameter glass turntable > 20 litre capacity > microwave power rating 800 W > grill power rating 1000 W

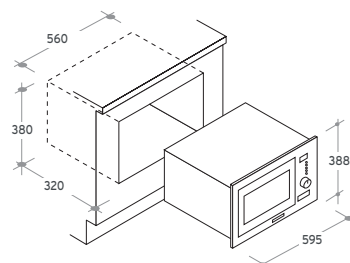

■ stainless steelMIC20 GDFX

WARMING DRAWER / WARMING DRAWER



CPWD140X BUILT-IN WARMING DRAWER

Programmes : keep warm function, pre-heating **crockery** > temperature freely adjustable from 30°C to 80°C > stainless steel finish > anti slip mat > illuminated on/off switch > telescopic full-depth pull-out drawer > max capacity 25kg > max absorbed power 620W > external dimensions H141 x W595 x D525

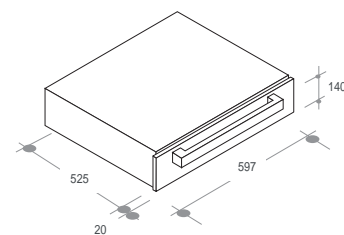

■ stainless steelCPWD140X



OVENS / IRON RANGE



FIR 715X IRON MULTI-FUNCTION OVEN

11 functions including **4 U-Cook functions** > electronic LED programmer > defrost function > variable grill > conventional cooking > fan cooking > **integral fan cooling system** > oven light > A class enamel-easy to clean oven interior > double glazed door > 53 litre capacity > energy class A

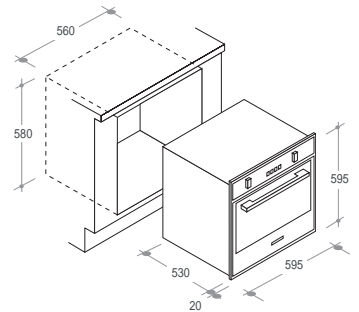

■ stainless steelFIR715X

Ucook



Controls & maintains humidity in the oven and helps retain the moisture content of even the most delicate pastries.



Rapid reduction of oven pre-heating times 0°C - 200°C in only 8 minutes!



Increases power by 50% compared to a standard grill.



Automatically adjusts fan speed to optimise air flow and oven temperature.



VarioFan

Automatically adjusts fan speed to optimise air flow and oven temperature for perfect cooking results.

OVENS / PLAN LIGHT RANGE



FPP 678/1X PYROLYTIC OVEN

8 functions > multi-function oven > electronic programmer > variable grill > fan cooking > Pyrolytic cleaning - 3 cycles > defrost function > oven light > integral fan cooling system > safety shelf system > 2 shelves > 1 roasting tray/grill pan > quadruple glazed door > 53 litre capacity > energy class A

Pyrolytic Cycle

An automatic self cleaning system uses intense heat (500°C) to burn off stubborn grease and food residues from the oven interior.

■ stainless steelFPP 678/1X

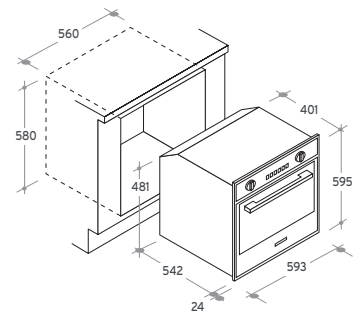

FPP 629 XL MULTI-FUNCTION OVEN

7 functions > multi-function oven > electronic programmer > variable grill > fan cooking > pizza program > defrost function > push pull controls > **integral fan cooling system** > oven light > A class enamel - easy to clean oven interior > safety shelf system > 2 shelves > 1 roasting tray/grill pan > 53 litre capacity > energy class A

■ stainless steelFPP 629 XL

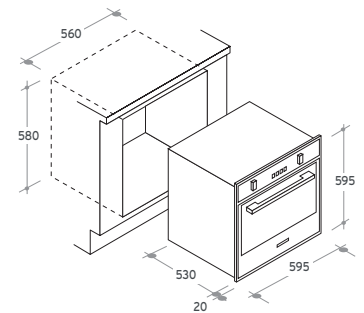

FPP 609X MULTI-FUNCTION OVEN

7 functions > multi-function oven > electronic programmer > variable grill > fan cooking > pizza function > defrost function > **integral fan cooling system** > oven light > A class enamel - easy to clean oven interior > safety shelf system > 2 shelves > 1 roasting tray/grill pan > 53 litre capacity > energy class A

■ stainless steelFPP 609X

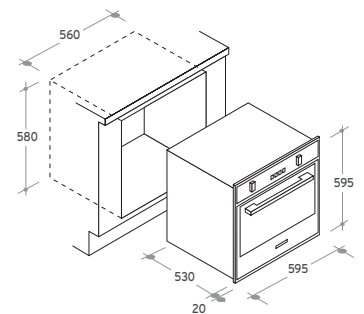

OVENS / PLAN LIGHT RANGE



FPP 407/1 FAN OVEN

Electronic LED Programmer > fan cooking > fan grilling > variable grill > defrost function > integral fan cooling system > A class clean enamel - easy to clean oven interior > safety shelf system > 2 shelves > 1 roasting tray/grill pan > oven light > double glazed door > 53 litre capacity > energy class A - 10%

- stainless steelFPP 407/1X
- blackFPP 407/1N
- whiteFPP 407/1W

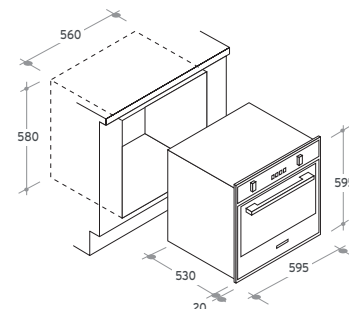

FPP 403/1 FAN OVEN

End of cooking timer > fan cooking > fan grilling > variable grill > defrost function > integral fan cooling system > A class clean enamel - easy to clean oven interior > safety shelf system > 2 shelves > 1 roasting tray/grill pan > oven light > double glazed door > 53 litre capacity > energy class A -10%

- stainless steelFPP 403/1X
- blackFPP 403/1N
- whiteFPP 403/1W

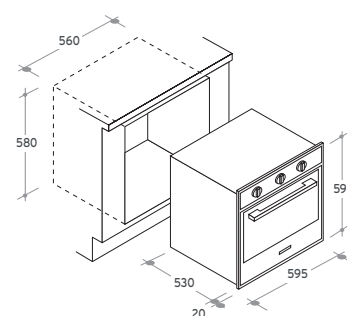

FST 201/1 STATIC OVEN

3 functions > dual zone grill > defrost function > oven light > A class enamel - easy to clean oven interior > safety shelf system > 2 shelves > 1 roasting tray/grill pan > double glazed door > 53 litre capacity > energy class A

- stainless steelFST 201/1X
- blackFST 201/1N
- whiteFST 201/1W

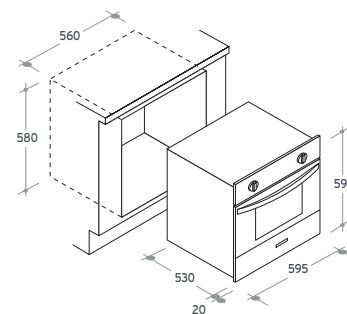



DOUBLE OVENS / PLAN RANGE



FDP 299/2 BUILT-IN MULTI-FUNCTION DOUBLE OVEN

Plan styling > **Bottom oven:** multi-function > electronic programmer > pizza function > grill > glass fascia panel (black only) > catalytic liners > oven light > double glazed oven door > 1 shelf and 1 grill pan > 49 litre capacity > energy class B > **Conventional Top oven** > variable grill > oven light > double glazed oven door > 1 shelf and 1 grill pan > 39 litre capacity > energy class A

-  stainless steelFDP 299/2 X
 -  black/stainless steel*FDP 299/2 NX
- *stainless steel knobs & handles only

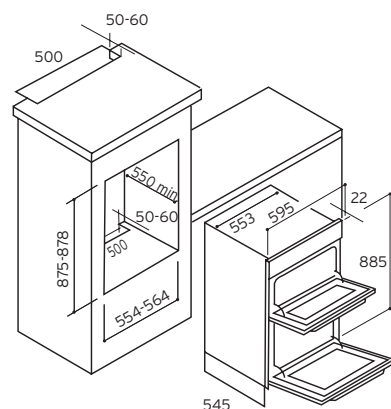

FDP 232/2 BUILT-IN FAN DOUBLE OVEN

Plan styling > **Bottom oven:** fan > electronic programmer > "easy to clean" enamel interior > oven light > double glazed oven door > 1 shelf and 1 grill pan > 54 litre capacity > energy class B > **Conventional Top oven** > variable grill > oven light > double glazed oven door > 39 litre capacity > energy class A

-  stainless steelFDP 232/2 X

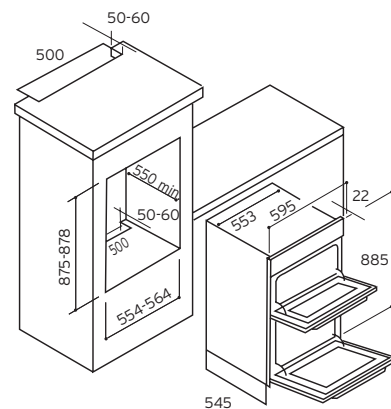

TCP 22/2 BUILT-UNDER FAN DOUBLE OVEN

Plan styling > **Bottom oven:** fan > electronic programmer > "easy to clean" enamel interior > oven light > double glazed oven door > 1 shelf and 1 grill pan > 43 litre capacity > energy class B > **Conventional Top oven** > variable grill > oven light > double glazed oven door > 1 shelf and 1 grill pan > 39 litre capacity > energy class A

-  stainless steelTCP 22/2 X

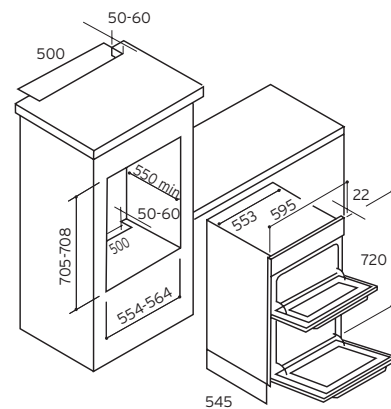





Duo

■ **DUO**

Advanced technology with a practical design in one unique solution.

Introducing a multi-function oven and a 6 place setting dishwasher that fits perfectly into a 60cm space.



DUO 609 X
COMBINED OVEN AND DISHWASHER

Oven specification

Multi-function electric oven and grill > 39 litre capacity > oven light > touch controls > 5 functions > double glazed door > energy class A

Dishwasher specification

6 IEC place settings > 6 programmes > 5 wash temperatures > 32 minute rapid programme > Eco bio 45°C programme > delicates programme > water consumption 9 litres > energy efficiency class A

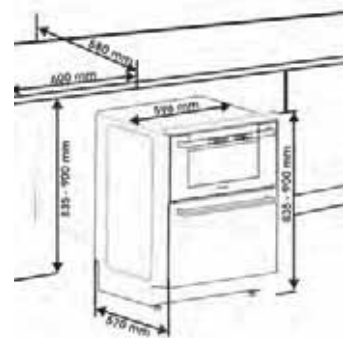

■ stainless steelDUO 609 X



Electric multi-function oven



Ceramic hob



6 place-setting dishwasher

■ **TRIO** - The big solution for small kitchens - combined oven, hob and dishwasher in a 60cm space.

Introducing a combination oven, hob and dishwasher that makes the most of limited space. With smart technology, smart design and unrivalled flexibility, the Trio offers a whole new dimension in kitchen design.

COMBINED OVENS / TRIO RANGE



TRIO 9503 X
COMBINED OVEN, CERAMIC HOB AND
DISHWASHER

Ceramic Hob Specification: 4 hi-light zones >
Oven Specification: multi-function electric oven and grill > oven interior light > 39 litre oven capacity > end of cooking timer > double glazed door > energy class A > **Dishwasher Specification:** 6 IEC place settings > 5 programmes > 32 minute rapid programme > Anti-overflow device > Water consumption 9 litres > energy efficiency class A > wash efficiency class A > drying efficiency class A > **dimensions** > height mm 850-920 (adjustable feet) > width mm 600 > depth mm 600

Optional matching stainless steel 60cm splashback PM60X and 60cm chimney hood CCT67X

■ stainless steelTRIO 9503 X



HOBS

A sleekly designed and solidly built range of 60cm and 75cm hobs include gas hobs with practical features that include quadruple ring burners and state of the art ceramic models that combine touch control with hi-light rapid response sprinter technology.

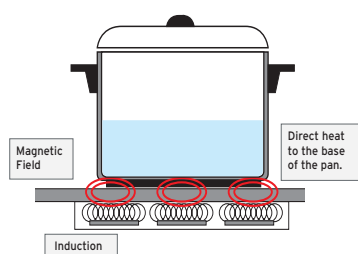

Induction Hob Efficiency

Induction hobs utilise Electromagnetic technology so that when a pan is placed on the induction heating zone it completes a magnetic circuit below the hob surface, causing only the contents of the pan to heat. It heats up a half litre of water in less than half the time and the surface temperature only reaches 81°C compared to a normal electric hob which can reach up to 410°C. Induction hobs are faster, more energy efficient and more controllable. It is also the safest type of hob, particularly if there are children present, as it will only heat up when the saucepan is placed on the hob.

Low Absorption Induction Hob

Using less than half the energy of normal induction hobs, the Candy CI 640 CBA low absorption hob comes complete with a 13 amp plug fitted, reducing the need for costly installation.



FLAME FAILURE DEVICE

In the event of the flame being extinguished accidentally a thermocouple device will automatically cut-off the gas supply.



AUTOMATIC IGNITION

Central control panels make it easier to reach and use the control knobs. Electronic ignition control is integrated in the control knobs, to allow single handed operation; the raised and inclined panel avoids overheating.



INDUCTION HOBS

Induction hobs operate at 90% efficiency and are more environmentally friendly than any other hob, consuming half the electricity of the next most efficient hob and one third the energy of an electric sealed plate hob.

HOBS 75CM / PLAN RANGE



CPG 75 SQPX 75CM GAS HOB

5 gas burners > **one touch ignition** > enamelled pan supports > 1 quadruple ring burner 4 kW > 2 rapid burners 2.5 kW > 1 semi-rapid burner 1.75 kW > 1 auxiliary burner 1 kW > single piece hob plate > flame failure device

CPG 75 SQGX available with cast iron pan supports (not shown)

PG 750 SXX as shown - all stainless steel finish with large central burner

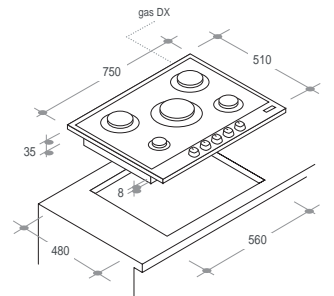

- stainless steelCPG 75 SQPX
- stainless steelCPG 75 SQGX
- all stainless steelPG750/1SXINT

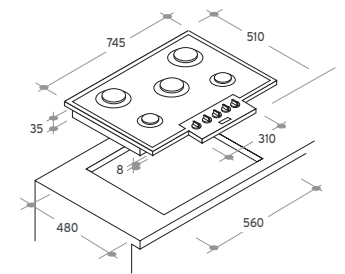

GAS HOBS / IRON RANGE



PGF750/1SQX 75CM GAS HOB

5 gas burners > **one touch ignition** > cast iron pan supports > 1 quadruple ring burner 3.5kW > 2 rapid burners 2.5kW > 1 semi rapid burner 1.75kW > 1 auxiliary burner 1.0kW > flame failure device

- stainless steelPGF750/1SQX

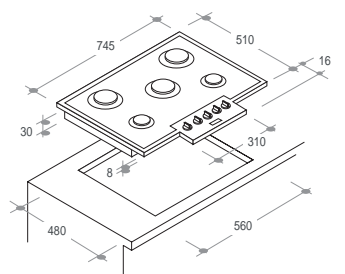

PGF640/1 60CM GAS HOB

4 gas burners > **one touch ignition** > 1 ultra rapid burner 3.3kW > 1 rapid burner 2.5kW > 1 semi rapid burner 1.75kW > 1 auxiliary burner 1.0kW > flame failure device > cast iron pan supports

- stainless steelPGF 640/1SX

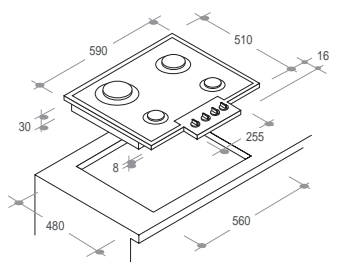

HOBS 75CM / PLAN RANGE



CPG 74 SQGX 75CM PLAN HOB

4 gas burners > one touch ignition > cast iron pan supports > flame failure device > 1 quadruple ring burner 4kW > 1 rapid burner 2.5kW > 1 semi-rapid burner 1.75kW > 1 auxillary burner 1kW

■ stainless steelCPG 74 SQGX

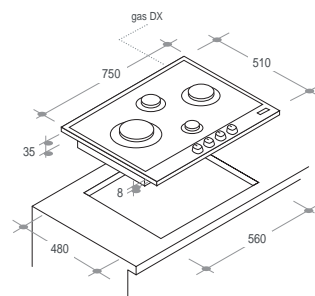

HOBS 75CM / PLAN RANGE



PV 750 SX 75CM PLAN HOB

5 gas burners > one touch ignition > 5 enamelled pan supports > flame failure device > 1 quadruple ring burner 3.5 kW > 2 rapid burners 2.5 kW > 2 semi-rapid burners 1.75 kW

■ stainless steelPV 750 SX

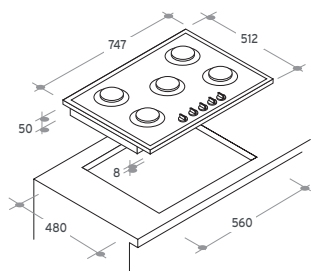

GAS HOBS / CLASSIC RANGE



CPGC 64 SQPGH 60CM GAS HOB

4 gas burners > one touch ignition > 1 quadruple burner 4.0 kW > 1 rapid burner 2.7 kW > 1 semi-rapid burner 1.7 kW > 1 auxillary burner 1kW > flame failure device > cast iron pan supports

■ charcoalCPGC 64 SQPGH

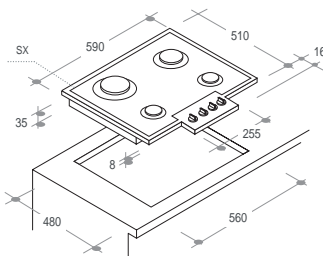

HOBS 60CM / PLAN RANGE



PG640/1SXXINT 60CM GAS HOB

4 gas burners > **one touch ignition** > 1 ultra rapid burner 3.5kW > 1 rapid burner 2.5kW > 1 semi-rapid burner 1.75kW > 1 auxiliary burner 1kW > flame failure device > 2 stainless steel pan supports > single cast hob plate

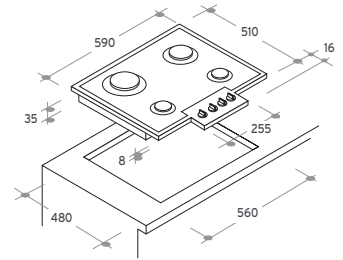

■ all stainless steelPG640/1SXXINT



CPG 64 SXX 60CM GAS HOB

4 gas burners > **one touch ignition** > 1 ultra rapid burner 3.5kW > 1 rapid burner 2.5 kW > 1 semi-rapid burner 1.75kW > 1 auxiliary burner 1kW > flame failure device > 2 stainless steel pan supports > single cast hob plate

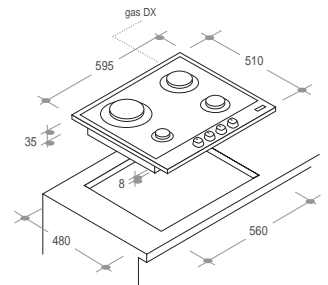

■ all stainless steelCPG 64 SXX
Available Autumn 2011



CPG 64SP 60CM GAS HOB

4 gas burners > **one touch ignition** > flame failure device > 1 ultra rapid burner 3.5 kW > 1 rapid burner 2.5 kW > 1 semi-rapid burner 1.75 kW > 1 auxiliary burner 1kW > 2 enamelled pan supports > single cast hob plate

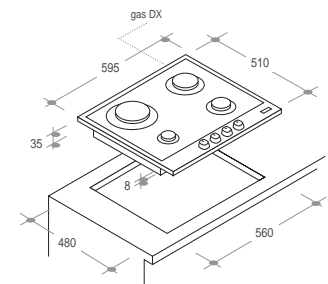

■ stainless steelCPG 64SPX
■ blackCPG 64SPN
□ whiteCPG 64SPB

HOBS 60CM / GAS HOBS



PV 640 SN 60CM DELUXE GAS GLASS HOB

High precision control knobs > **one touch ignition** > flame failure device > 4 gas burners > 2 rapid burners 2.5 kW > 2 semi-rapid burners 1.75 kW > 4 enamelled pan supports

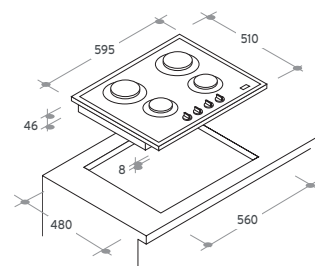

■ blackPV 640 SN



CLG 64 SP GAS HOB

4 gas burners > one touch ignition > flame failure device > 1 rapid burner 2.7 kW > 2 semi-rapid burners 1.7 kW > 1 auxiliary burner 1.0 kW > 2 enamelled pan supports

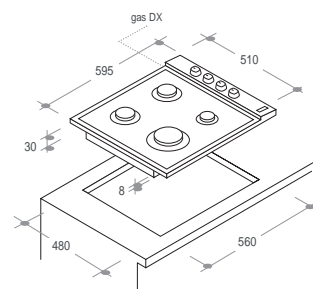

■ stainless steelCLG 64 SPX
 ■ blackCLG 64 SPN
 □ whiteCLG 64 SPB
 ■ stainless steelCLG 64 SGX
 with cast iron pan supports

HOBS 60CM / ELECTRIC HOBS



PLE 64 60CM ELECTRIC HOB

High precision controls > 4 solid electric rapid hot plates > 2 hotplates Ø 180 mm 2.0 kW > 2 hotplates Ø 145 mm 1.5 kW > single-cast hob plate

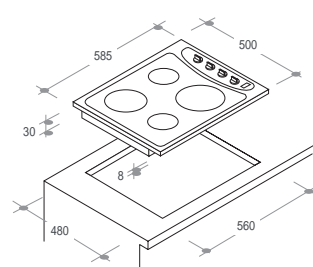

■ stainless steelPLE 64 X
 ■ blackPLE 64 N
 □ whitePLE 64 W

HOBS / HI-LIGHT SPRINTER CERAMIC



PVD 742/1 75CM TOUCH CONTROL HI-LIGHT CERAMIC HOB

Digital touch controls > end of cooking timer on a cooking area of your choice > extendable rear-right element > **4 hi-light rapid sprinter cooking zones** > 1 hi-light zone Ø 190mm 1.8kW > 1 hi-light extendable double zone Ø 155/190mm 1.8kw > 1 hi-light extendable double Ø 180/275mm 0.9+1.5kW > 1 hi-light zone Ø 155mm 1.2kW > easy to clean cooking surface > child safety lock

- stainless steel (trim only)PVD 742/1X
- black (no trim)PVD 742/1N

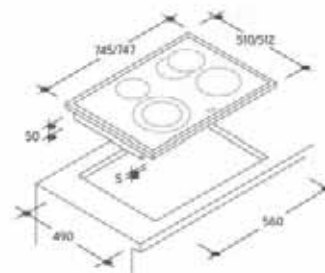

CH 642 60CM TOUCH CONTROL HI-LIGHT CERAMIC HOB

Digital touch controls > end of cooking timer on a cooking area of your choice > easy to clean cooking surface > **4 hi-light rapid sprinter cooking zones** > 1 hi-light zone Ø 155mm 1.2kW > 1 hi-light double zone Ø 130/220mm .75 + 1.45kW > 2 hi-light zones Ø 190mm 1.8kW > child safety lock

- stainless steel (front trim only)CH 642X
- black (bevelled front edge)CH 642B

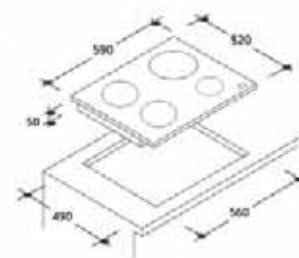

HOBS / INDUCTION HOB



CI 640 CBA 60CM INDUCTION HOB - LOW ABSORPTION

Digital touch controls > timer on each zone > digital clock > **4 induction zones including 1 booster zone** > 1 zone Ø 210mm 2-2.6kw > 1 zone Ø 180mm 2.0kw > 2 zones Ø 180mm 1.4kw > easy to clean cooking surface > child safety lock > fitted with a 13 amp plug

- black (no trim)CI 640 CBA

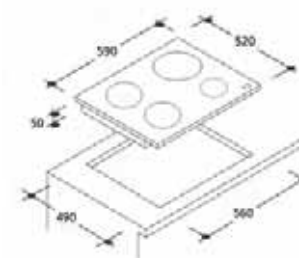

HOBS / INDUCTION HOB



CI 640 C 60CM INDUCTION HOB

Digital touch controls > timer on each zone > digital clock > **4 induction zones** > 1 zone Ø 210mm 2kW > 1 zone Ø 180mm 2kW > 2 zones Ø 180mm 1.4kW > child safety lock

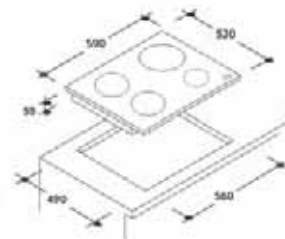

■ blackCI 640 C

HOBS / HI-LIGHT CERAMIC



CH 64M 60CM HI-LIGHT CERAMIC HOB

Traditional high precision control knobs > 4 heat-on warning lights > easy to clean surface > **4 hi-light rapid sprinter cooking zones** > 1 hi-Light zone Ø 220mm 2.3 kW > 1 hi-light zone Ø 190mm 1.8 kW > 2 hi-light zones Ø 155mm 1.2 kW

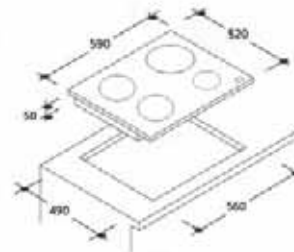

■ stainless steel (front trim only) CH 64MX
■ black (bevelled front edge) CH 64MB

HOBS / DOMINO HOBS



CDG 31 SPX GAS HOB

1 gas wok burner 3.8kW > flame failure device > enamel pan support > one touch ignition

■ stainless steel CDG 31 SPX

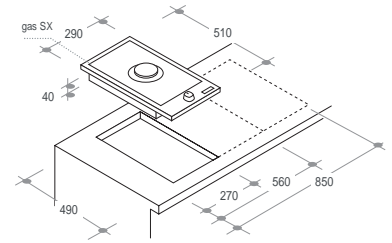

CDG 32 SPX GAS HOB

2 gas burners > flame failure device > 1 ultra rapid burner 3.0kW > 1 auxiliary burner 1.0kW > one touch ignition > enamel pan support

■ stainless steel CDG 32SPX

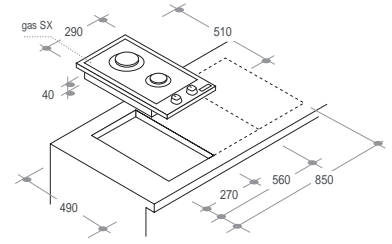

CDH 32 X CERAMIC HOB

2 cooking zones > 1 zone 180mm 1.8kW > 1 zone 140mm 1.2kW > easy to clean surface

■ stainless steel CDH 32 X

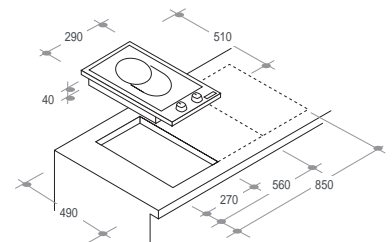

CDI 32 B INDUCTION HOB

Digital touch controls > 2 heat-on warning lights > easy to clean surface > 2 induction zones including 1 with booster > cooking timer

Also available is a Ceramic Hob - CDH 32C with digital touch control > 2 cooking zones > 1 zone 180mm 1.8kW > 1 zone 140mm 1.2kW > cooking timer > child safety lock.

■ black (bevelled edge) CDI 32B

■ black (bevelled edge) CDH 32C

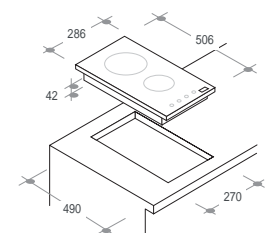

HOBS / DOMINO HOBS



CDE 32 X ELECTRIC HOB

1 hotplate 180mm 1.5kW > 1 hotplate 145mm 1.5kW >
1 rapid zone > high precision control knobs

■ stainless steel CDE 32X

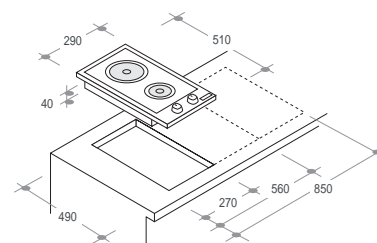

CDVG 30 X GRIDDLE

Residual heat indicator > cooking zone 250x400mm
1.5kW > high precision control knob

■ stainless steel CDVG 30X

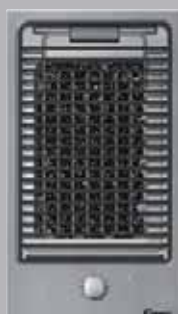
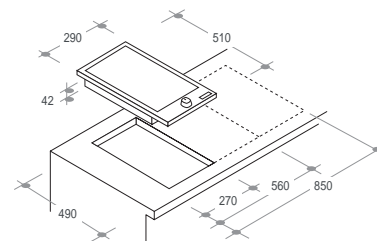

CDB 30 X BBQ

Cooking area 220x320mm 2.4kW > enamel support
> adjustable temperature control

■ stainless steel CDB 30X

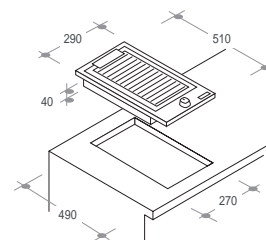

CDF 30 X FRYER

Deep fat fryer > cooking basket > lid > adjustable
temperature control

■ stainless steel CDF 30 X

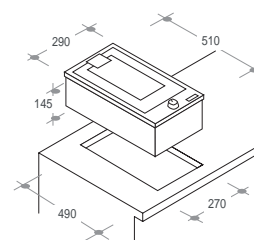



■ HOODS

Candy's hoods whether chimney or decor style, in futuristic or more traditional design, incorporate the very latest electronic touch control technology. They offer great performance, high extraction rates, low noise levels and bright halogen hob and work surface illumination.



HALOGEN LIGHTS

Illuminate the hob with bright halogen lights - improving the whole cooking experience.



DECOR HOODS

Candy combines glass and stainless steel to enhance the overall impact of your kitchen.



EXTRACTION RATES

Candy hoods are amongst the quietest and most efficient available capable of removing most cooking odours effortlessly.

DECOR HOODS / ISLAND TUBE HOOD



CIDT 61 X 40CM ISLAND TUBE HOOD

Motor 250 W > Extraction flow rate 740 m³/h > 4 speeds operated by electronic touch controls > 2 halogen lights > perimeter filtration

■ stainless steelCIDT 61 X

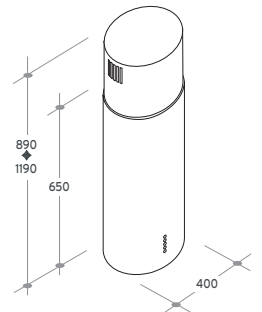

DECOR HOODS / ISLAND CUBE HOOD



CIDC 61 X 70CM ISLAND TUBE HOOD

Motor 250 W > extraction flow rate 740 m³/h > electronic touch controls > 4 halogen lights > perimeter filtration

■ stainless steelCIDC 61 X

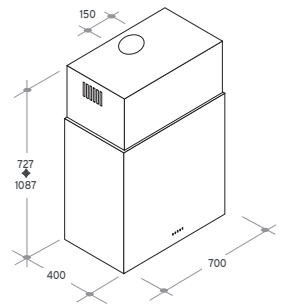

DECOR HOODS / TUBE HOOD



CDT 61 X 40CM TUBE DECOR HOOD

Motor 250 W > Extraction flow rate 550 m³/h > 4 speeds operated by electronic touch controls > 2 halogen lights > filter saturation indicator > perimeter filtration > Convertible: extraction or recirculation > Charcoal filter optional extra

■ stainless steelCDT 61 X

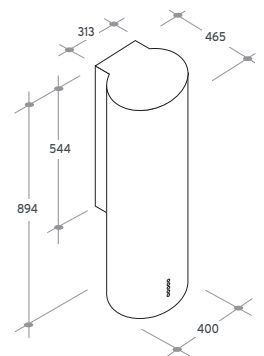

DECOR HOODS / CUBE HOOD



CDC 61 X 60CM CUBE DECOR HOOD

Motor 250 W > extraction flow rate 740 m³/h > 3 speeds operated by push button controls > 2 halogen lights > filter saturation indicator > perimeter filtration > Convertible: extraction or recirculation > Charcoal filter optional extra

■ stainless steelCDC 61X

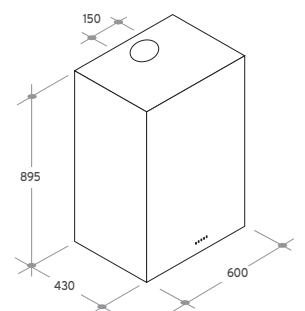

DECOR HOODS / PLAN RANGE



CMB 90 X 90CM HOOD

Turbo motor 150 W > extraction flow rate 370 m³/h
> 3 speeds operated by push button controls > 2 lights > convertible: extraction or recirculation > washable metal grease filter > optional charcoal filters

■ stainless steelCMB 90 X

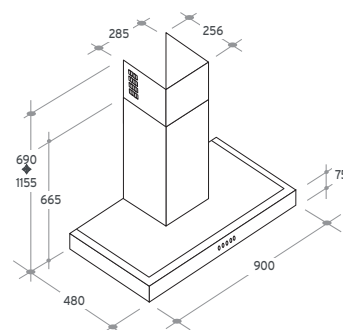

DECOR HOODS / PLAN RANGE



CMB 60 X 60CM HOOD

Turbo motor 150 W > extraction flow rate 370 m³/h
> 3 speeds operated by push button controls > 2 lights > convertible: extraction or recirculation > washable metal grease filter > optional charcoal filters

■ stainless steelCMB 60 X

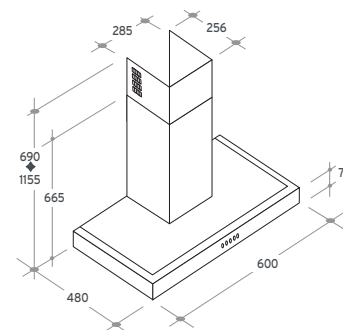

DECOR HOODS



CVM 95 X 90CM DECOR HOOD

Turbo motor 230 W > extraction flow rate 550 m³/h
> 3 speeds operated by push button controls > 2 halogen lights > convertible: extraction or recirculation > washable metal grease filter > optional charcoal filter

■ stainless steelCVM 95 X

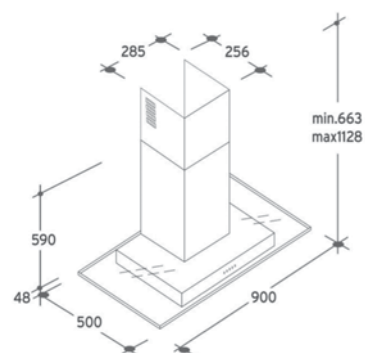

DECOR HOODS



CRD 93 X 90CM ROUND DECOR HOOD

Turbo motor 230 W > extraction flow rate 550 m³/h
> 3 speeds operated by push button controls > 2 lights > convertible: extraction or recirculation > washable metal grease filter > charcoal filters

■ stainless steelCRD 93 X

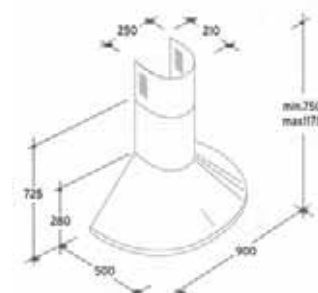

DECOR HOODS



CCR 616 X 60CM ROUND DECOR HOOD

Turbo motor 150 W > extraction flow rate 450 m³/h
> 3 speeds operated by slider controls > 2 lights > convertible: extraction or recirculation > washable metal grease filter > optional charcoal filter

■ stainless steelCCR 616 X

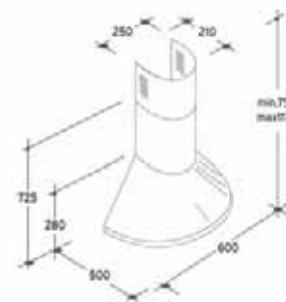

DECOR HOODS



CGM 91 / CGM 61 90 & 60CM GLASS DECOR HOOD

Turbo motor 150 W > extraction flow rate 450 m³/h
> 3 speeds operated by push button control > tempered safety glass > 2 halogen lights > convertible: extraction or recirculation > washable metal grease filter.

Also available in 60cm - CGM 61X

■ stainless steelCGM 91 X
■ stainless steelCGM 61 X

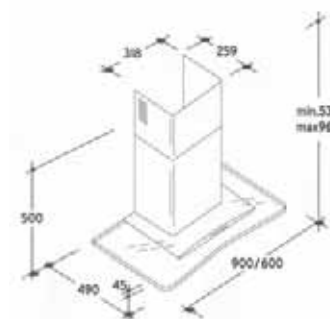

CHIMNEY HOODS



CCT 97 / CCT 67 90 & 60CM CHIMNEY HOODS

Turbo motor 230W > extraction flow rate 550m³/h
> 3 speeds operated by push button controls > 2 halogen lights > convertible: extraction or recirculation > washable metal grease filters > charcoal filters

Also available in 60cm - CCT 67

■ stainless steelCCT 97 X
■ stainless steelCCT 67 X
■ blackCCT 67 N
■ whiteCCT 67 W

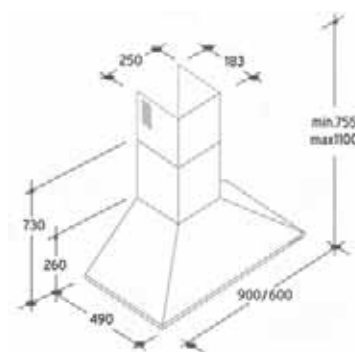

INTEGRATED HOODS



CBP 612 60CM WIDE

Motor 100W > extraction flow rate 230m³/h > 3 speeds > 1 x 40W bulb > convertible: extraction or recirculating > acrylic filter

- greyCBP 612 GR
- blackCBP 612 N
- whiteCBP 612 W

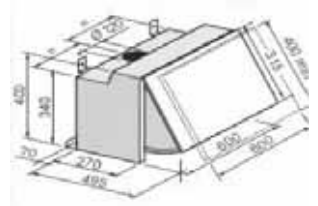

CANOPY HOODS



CBG 61 60CM WIDE

Motor 100W > extraction flow rate 180m³/h > 3 speeds operated by slider > 1 x 40W bulb > convertible: extraction or recirculation > acrylic filter

- silverCBG 61 X
- blackCBG 61 N
- whiteCBG 61 W

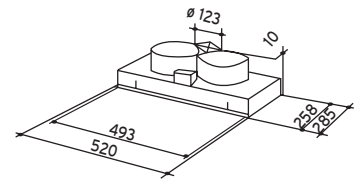

CONVENTIONAL HOODS



CFT 610 60CM WIDE

Motor 120W > extraction flow rate 240m³/h > 3 speeds > slider controls > 1 x 40W bulb > convertible extraction or recirculation > acrylic filter

- silverCFT 610S
- blackCFT 610N
- whiteCFT 610W

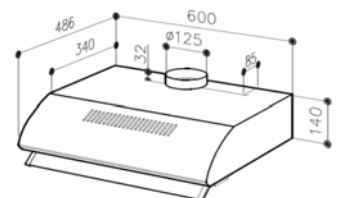



■ DISHWASHERS & HOME LAUNDRY

Candy's integrated laundry and dishwashers are an ingenious blend of styling and technology, offering an outstanding performance, they are extremely efficient and are exceedingly quiet.

Home Laundry



Large Load Capacity - The Candy CDB 754 integrated washer dryer is capable of handling a 7kg wash & 5kg dry load, perfect for busy families.

Dishwashers



The Eco CDI 22E10 dishwasher uses just 10 litres to wash a full load. The water is filtered and recirculated over 7,800 times to ensure an A rated wash performance, whilst maximising water usage.

The Candy CDI 3530 dishwasher features a combination of 3 baskets and 14 place settings and provides additional valuable loading space in the top basket. The top basket is perfect for small coffee cups, saucers, side plates and cooking utensils.



All Candy full size dishwashers are triple A rated for energy efficiency, wash and drying performance.



TIME SAVING WASHING MACHINE

The CDB 754 is perfect for busy people - a 59 minute programme means that you can wash and dry 3 garments in under an hour, perfect for those forgotten items.



SELF-CLEANING FILTER

Self-cleaning stainless steel filter: the stainless steel microfilter in Candy dishwashers keeps water constantly clean for maximum wash efficiency and an end of cycle jet of water expels any impurities trapped in the filter.



ADJUSTABLE BASKETS

Adjustable Baskets: the upper basket in Candy dishwashers are height adjustable and have a range of between 21 and 26 cm, giving the lower basket a range of between 26 and 31 cm.

FULLY INTEGRATED DISHWASHERS



CDI 3530-80

FULLY INTEGRATED DISHWASHER

14 IEC place settings > 3 baskets > 5 programmes > 4 wash temperatures > 32 minute rapid programme > programme selection by button > half load button > adjustable upper basket > front access levelling facility > 3-6-9 hrs start delay LED > salt consumption light > balanced door > self-cleaning micro filter > energy efficiency class A > wash efficiency class A > drying efficiency class A

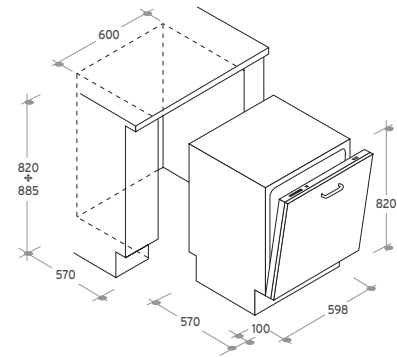

CDI 22E10/3

FULLY INTEGRATED DISHWASHER

10 litre water consumption > 12 IEC place settings > 5 programmes > 4 wash temperatures > 32 minute rapid programme > programme selection by button > half load button > adjustable upper basket > front access levelling facility > delay start LED > salt consumption light > balanced door > self-cleaning stainless steel micro filter > energy efficiency class A > wash efficiency class A > drying efficiency class A

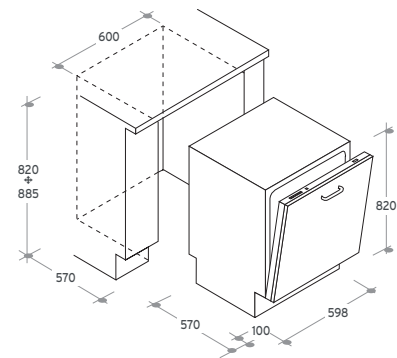

CDI 1012/3-80

FULLY INTEGRATED DISHWASHER

12 place settings > 5 programmes > 4 wash temperatures > 32 minute rapid programme > water softener settings > balanced door > adjustable upper basket > self-cleaning stainless steel micro filter > energy efficiency class A > wash efficiency class A > drying efficiency class A

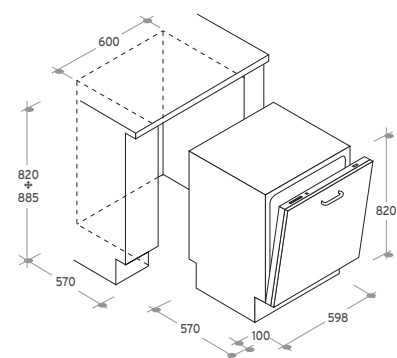

INTEGRATED DISHWASHER



CDS 420 INTEGRATED DISHWASHER

12 place settings > **5 programmes** > **5 wash temperatures** > **32 minute rapid programme** > adjustable upper basket > self-cleaning stainless steel micro filter > half load button > balanced door > salt indicator light > energy efficiency class A > wash efficiency class A > drying efficiency class A

- stainless steel fasciaCDS 420X
- black fasciaCDS 420N
- white fasciaCDS 420W

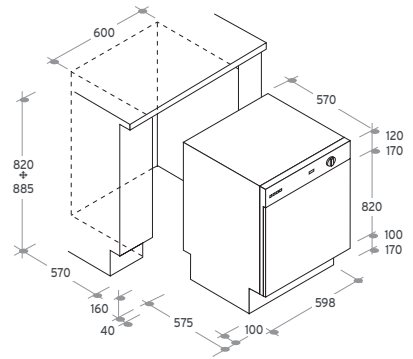

FULLY INTEGRATED SLIMLINE DISHWASHER



CDI 4545 45CM FULLY INTEGRATED DISHWASHER

9 IEC place settings > LED digital display > 7 programmes > 4 wash temperatures > adjustable upper basket > 24 hour start delay > programme selection button > intensive wash programme > rapid programme > energy efficiency class A > washing efficiency class A > drying efficiency class A

- whiteCDI 4545

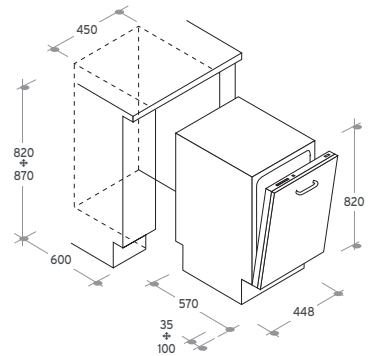

FULLY INTEGRATED WASHER DRYER



CDB 754D/1-80 FULLY INTEGRATED WASHER DRYER

1400 r.p.m. > 7kg wash and 5kg drying capacity > stainless steel drum assembly > 14 wash programmes **Fuzzy Logic** > start delay (up to 23 hours) > LED display > digital countdown indicator > rapid 14, 30 & 44 minute programme > half load option > mixed wash programme > delicates/ hand wash programme > stain buster button > allergy care button > automatic variable capacity > **3 dry programmes** > high dry button > self cleaning filter > cold fill only > adjustable feet > energy efficiency class A

whiteCDB 754/1D-80

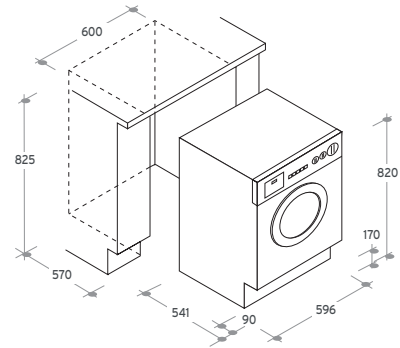

FULLY INTEGRATED WASHING MACHINE



CWB 714D-80 FULLY INTEGRATED WASHING MACHINE

1400 r.p.m. > 7kg wash capacity > stainless steel drum assembly > 13 programmes > rapid 14, 30 & 44 minute programmes > LED display > digital countdown indicator > start delay (up to 23 hours) > half load option > fuzzy logic > pre-wash programmes > mixed wash programme > delicate/ hand wash programme > stain buster button > easy iron button > allergy care button > automatic variable capacity > self cleaning filter > cold fill only > adjustable feet > energy efficiency class A+

whiteCWB 714D-80

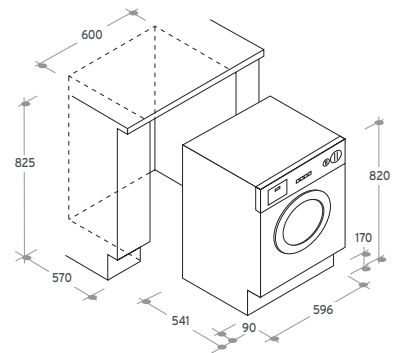
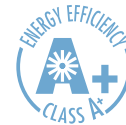

FULLY INTEGRATED WASHER DRYER



CDB 264-80 FULLY INTEGRATED WASHER DRYER

1200 r.p.m. > 6kg wash and 4kg drying capacity > stainless steel drum assembly > 18 wash programmes > 32 minute wash programme > 3 drying programmes > fuzzy logic > start delay (up to 9 hours) > automatic variable capacity > variable thermostat > stain buster button > high dry button > drying time selection control > oval tub > self cleaning filter > crease free final cool tumble > cold fill only > fast iron button > cupboard dry ironing > adjustable feet > energy efficiency class B

whiteCDB 264-80

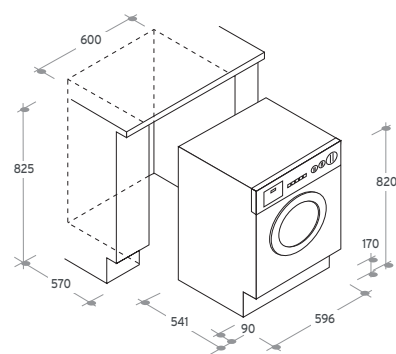

FULLY INTEGRATED WASHING MACHINE



CWB 1206-80 FULLY INTEGRATED WASHING MACHINE

1200 r.p.m. > 6kg wash capacity > stainless steel drum assembly > 15 programmes > 32 minute wash programme > start delay (up to 9 hours) > fuzzy logic > pre-wash programme > half load option > automatic variable capacity > variable thermostat > variable spin speed from 0-1200r.p.m. > extra rinse button > allergy care button > easy iron button > oval tub > self cleaning filter > cold fill only > adjustable feet > energy efficiency class A+

whiteCWB 1206-80

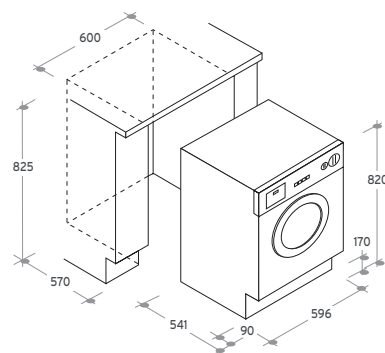



REFRIGERATION

From modern compact fridges to large capacity fridge freezers our integrated appliances will co-ordinate with any kitchen setting. Whether it's frost free technology or simply an extra large integrated fridge you require we have a range of innovative cooling products to suit every requirement.



Energy Efficiency

All Candy refrigeration are A rated for energy efficiency.



Candy Frost Free Fridge Freezers prevent frost formation in the freezer section, which means never having to defrost the freezer.



MAINTAINS CONSTANT TEMPERATURE

Candy's 'turbo cooling' feature ensures even temperature distribution throughout the refrigerator.



VERSATILE STORAGE SOLUTIONS

Adjustable shelving allows large or bulky items to be stored safely.



GLASS SHELVING

Easy care glass shelving ensures maximum hygiene.

FULLY INTEGRATED FRIDGE FREEZER / REFRIGERATION



CXS 7204A FROST FREE SIDE BY SIDE FRIDGE FREEZER

Freezer rating. ❄️❄️❄️ > total net capacity 558 litres (19.7 cu.ft) > net refrigerator capacity 348 litres (12.3 cu.ft) > net freezer capacity 210 litres (7.4 cu.ft) > electronic control > energy efficiency class A > climate class N-ST > dimensions H x W x D 1757 x 892 x 736 mm

Refrigerator
4 adjustable glass shelves > 5 door shelves > 3 pull out refrigerator drawers (2 with humidity control) > dairy compartment

Freezer
3 glass shelves > 6 door shelves > 2 transparent freezer drawers > freezing capacity 10kg



■ silverCXS 7204A

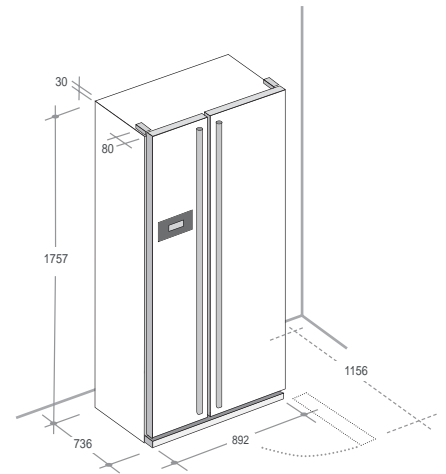
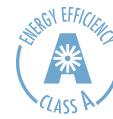

CFBC 3150A UK FRIDGE FREEZER

Freezer rating. ❄️❄️❄️ > total gross capacity 281 litres (9.9 cu.ft) > net refrigerator 203 litres (7.2 cu.ft) > net freezer capacity 60 litres (2.1 cu.ft) > 24hr freezer capacity 4kg > climate class N/ST > energy efficiency class A > glass shelves > automatic defrosting (fridge) > reversible doors > **housing dimensions** > height mm 1772÷1776 > width mm 560 > depth mm 550

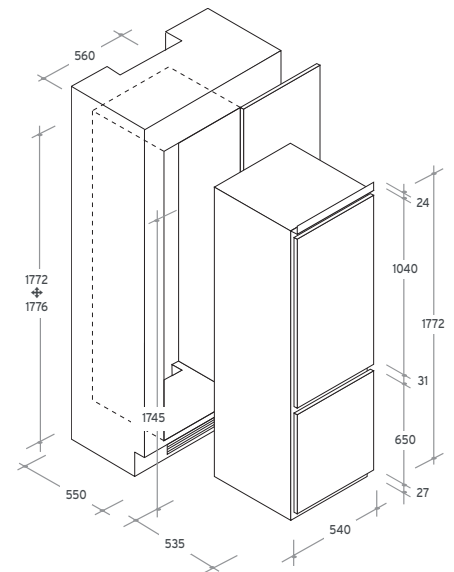
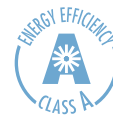

FULLY INTEGRATED FRIDGE FREEZER / REFRIGERATION

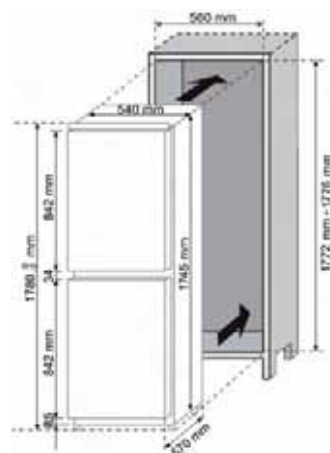
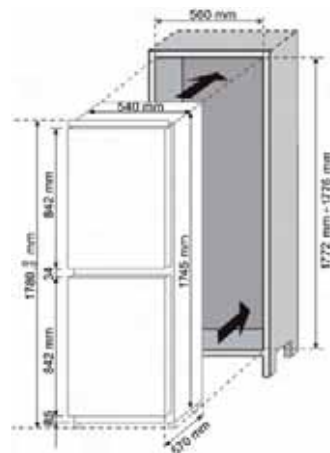
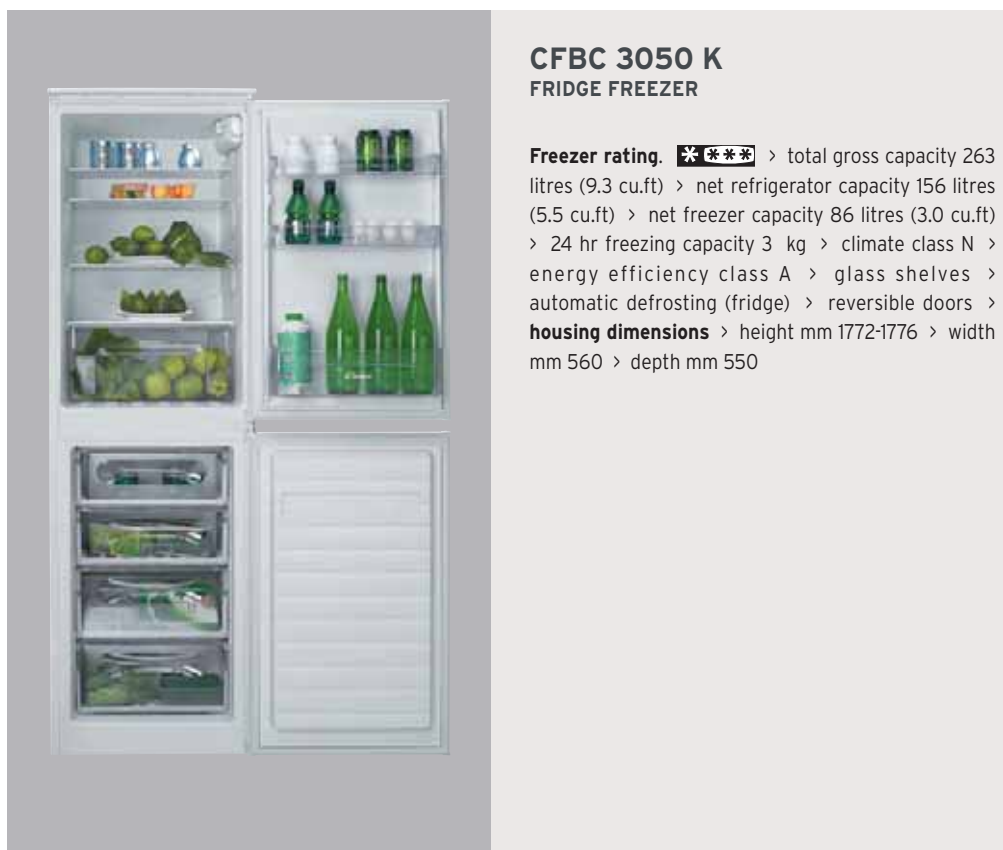

FULLY INTEGRATED FRIDGE / REFRIGERATION

CIO 225/1 AG
REFRIGERATOR

Freezer rating. ❄️❄️❄️ > total gross capacity 195 litres (6.9 cu.ft) > net refrigerator capacity 175 litres (6.2 cu.ft) > net freezer capacity 17 litres (0.6 cu.ft) > 24hr freezing capacity 2 Kg > climate class N > energy efficiency class A > automatic defrosting > glass shelves > reversible door > **housing dimensions** > height mm 1225 ÷ 1227 > width mm 560 > depth mm 550

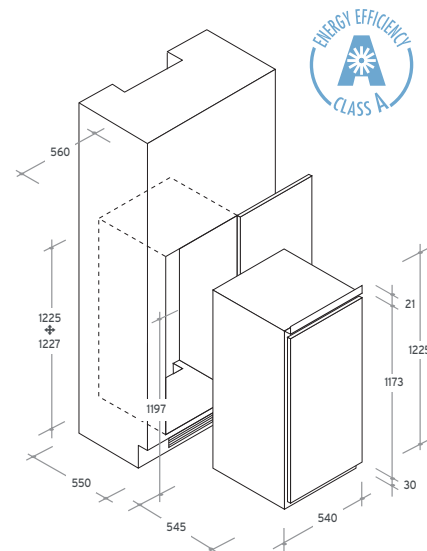

FULLY INTEGRATED FRIDGE / REFRIGERATION

CBL150/1AG
BUILT-IN LARDER FRIDGE

Total gross capacity 140 litres (4.9 cu.ft) > net refrigerator capacity 128 litres (4.5 cu.ft) > climate class N > energy efficiency class A > automatic defrosting > glass shelves > reversible door > **housing dimensions** > height mm 874 ÷ 878 > width mm 560 > depth mm 550

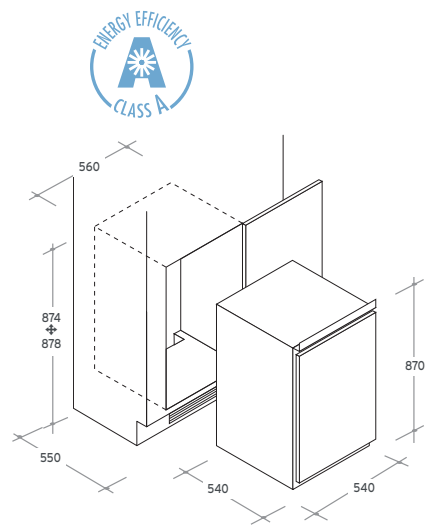

FULLY INTEGRATED FREEZER / REFRIGERATION

CIF 130/1
BUILT-IN FREEZER

Freezer rating. ❄️❄️❄️ > total gross capacity 109 litres (3.9 cu.ft) > net freezer capacity 99 litres (3.5 cu.ft) > 24 hr freezing capacity 10.5 Kg > climate class N > energy efficiency class A > manual defrosting > reversible door > on/off - green light > fast freeze - yellow light > freezer warning - red light > **housing dimensions** > height mm 875 ÷ 878 > width mm 560 > depth mm 550

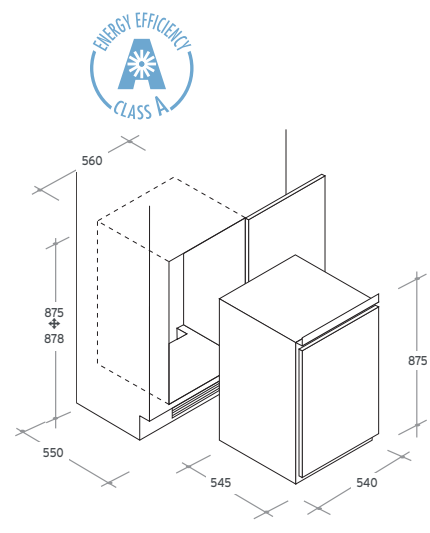

FULLY INTEGRATED FRIDGE / REFRIGERATION



CRU 164/1 AK BUILT-UNDER REFRIGERATOR

Freezer rating. * ** ** > total gross capacity 128 litres (4.5 cu.ft) > net refrigerator capacity 111 litres (3.9 cu.ft) > net freezer capacity 17 litres (0.6 cu.ft) > climate class N > energy efficiency class A > glass shelves > automatic fridge defrosting > reversible door > 24hr freezing capacity 2Kg > **housing dimensions** > height mm 820÷870 > width mm 600 > depth mm 550

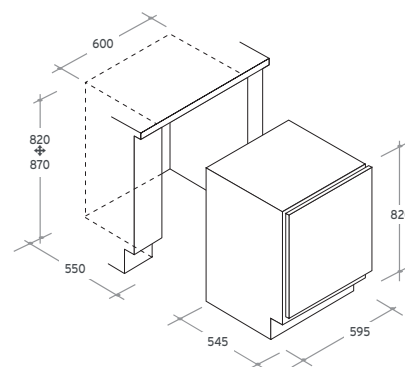

FULLY INTEGRATED LARDER FRIDGE / REFRIGERATION



CRU 160/1 AK BUILT-UNDER LARDER FRIDGE

Total gross capacity 147 litres (5.2 cu.ft) > net refrigerator capacity 140 litres (4.9 cu.ft) > climate class SN > energy efficiency class A > automatic defrosting > reversible door > **housing dimensions** > height mm 820÷870 > width mm 600 > depth mm 550

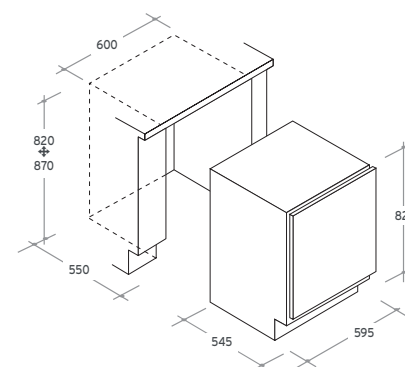

FULLY INTEGRATED FREEZER / REFRIGERATION



CFU 130/2AK BUILT-UNDER FREEZER

Freezer rating. * ** ** > total gross capacity 120 litres (4.2 cu.ft) > net freezer capacity 105 litres (3.6 cu.ft) > 24 hr freezing capacity 5 Kg > climate class SN > energy efficiency class A > reversible door > manual defrosting > on/off - green light > fast freeze - yellow light > freezer warning - red light > **housing dimensions** > height mm 820÷870 > width mm 600 > depth mm 550

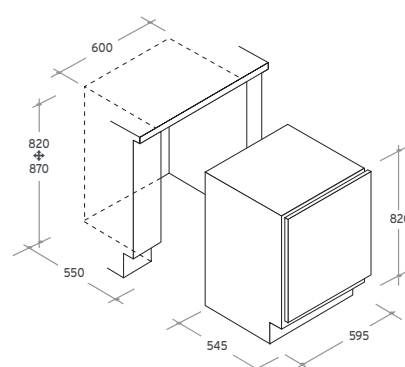

WINE COOLERS / REFRIGERATION

CCVB 110T
 BUILT-IN WINE COOLER

60cm wide > total capacity 110 litres > stores 24 bottles > 8 wooden shelves > blue LED light > adjustable temperature control 4-18 C

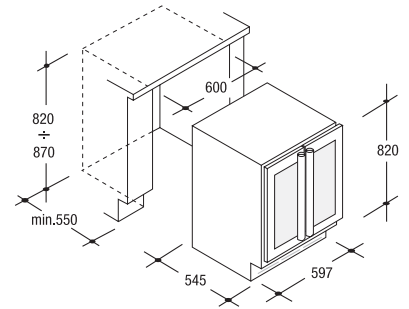
CCVB 120
 BUILT-IN WINE COOLER

60cm wide > total capacity 120 litres > stores 35 bottles > LED display > 4 telescopic wooden shelves > blue LED light > adjustable temperature control 4 - 18°C

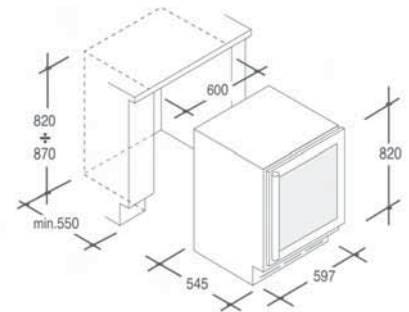
CCVB 60UK
 BUILT-IN WINE COOLER

30cm wide > total capacity 57 litres > stores 12 bottles > 4 wooden shelves > LED display > light > adjustable temperature control 4 - 18°C > front vent > adjustable feet

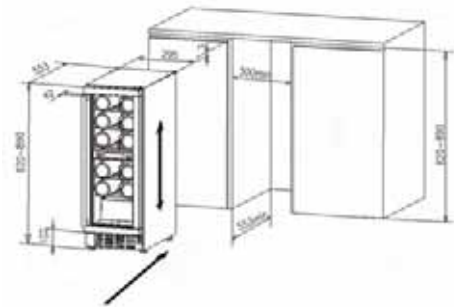
CCVB 25T UK
 BUILT-IN WINE COOLER

15cm wide > Total gross capacity 20 litres > stores 7 bottles > LED display with light > adjustable temperature control from 8 - 22°C transparent glass door > front vent

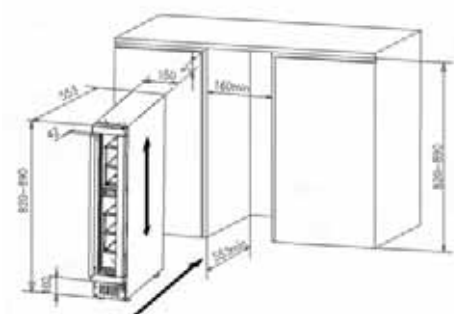

TECHNICAL SPECIFICATIONS / REFRIGERATION

| Model | REFRIGERATION | | | | | | | | | |
|-------------------------------|--------------------------------|----------------------------------|------------|--------------------------------|-----------|-----------------|----------------------------------|-----------------------|------------------------|-------------------------------|
| | CXS7204 | CFBC 3150 | CFBF 3050 | CFBC 3050 | CIO225/1A | CBL150/1AG | CIF130/1 | CRU 164/1AK | CRU160/1AK | CFU130/2AK |
| Product description | Side by Side Fridge Freezer | Fridge freezer Fridge Freezer | Frost Free | Fridge freezer Refrigerator | Built-in | Built-in Larder | Built-in Freezer Refrigerator | Built-under Larder | Built-under Freezer | Built-under Freezer rating |
| Main characteristics | | *** | *** | *** | *** | | *** | *** | | *** |
| Rapid freeze indicator light | - | - | - | - | - | - | - | • | - | •• |
| Adjustable thermostat | • | • | • | • | • | • | • | • | • | - |
| Door shelves | | 4 | 3 | 3 | 3 | 3 | - | 2 | 2 | - |
| Crisper | 3 | 1 | 1 | 1 | 2 | 2 | - | 1 | 1 | - |
| Glass shelves | 4/3 | 4 | 4 | 4 | 4 | 3 | - | 1 | 2 | - |
| Freezer Drawers | 2 | - | 4 | 4 | - | - | - | - | - | 3 |
| Reversible doors | • | • | • | • | • | • | • | • | • | • |
| Number of compressors | 1 | 1 | 1 | 1 | 1 | 1 | 1 | 1 | 1 | 1 |
| Technical Data | | | | | | | | | | |
| Total gross capacity (l) | - | 281 | 255 | 263 | 195 | 140 | 109 | 128 | 147 | 120 |
| Net refrigerator capacity (l) | 348 | 203 | 156 | 156 | 175 | 128 | - | 111 | 140 | - |
| Net freezer capacity (l) | 210 | 60 | 78 | 86 | 17 | - | 99 | - | - | 102 |
| 24 hr freezing capacity (kg) | 10 | 4 | 3 | 3 | 2 | - | 10.5 | 2 | - | 5 |
| Climatic class (l) | N/ST | N/ST | N | N | N | N | N | N | SN | SN |
| Manual defrosting | - | • | - | • | • | - | • | • | - | • |
| Frost free | • | - | • | - | - | - | - | - | - | - |
| Rising time (h) | 10 | 15 | 12.5 | 16 | 11.6 | - | 13.6 | 10 | - | 17 |
| Annual consumption (kWh) (2) | 551 | 266 | 317 | 310 | 252 | 150 | 208 | 230 | 153 | 215 |
| Energy efficiency class (3) | A | A | A | A | A | A | A | A | A | A |
| Noise level dB (A) (re 1 pw) | 47 | 42 | 42 | 40 | 40 | 40 | 39 | 40 | 40 | 41 |
| Appliance category (4) | | 7 | | | 7 | 1 | 8 | 7 | 1 | 8 |
| Width of cavity (mm) | 892 | 560 | 560 | 560 | 560 | 560 | 560 | 600 | 600 | 600 |
| Min. depth of cavity (mm) | 736 | 550 | 550 | 550 | 550 | 550 | 550 | 550 | 550 | 550 |
| Height of cavity (mm) | 1757 | 1772÷1776 | 1772-1776 | 1772-1776 | 1225÷1227 | 874÷878 | 875÷895 | 820÷870 | 820÷870 | 820÷870 |

TECHNICAL SPECIFICATIONS / HOODS

| Model | HOODS | | | | | | | | | | | | | | | |
|------------------------------|-------------|-------------|---------|---------|---------|---------|---------|-------------|-------------|---------|---------|---------|---------|--------|------------|----------|
| | CIDT 61 | CIDC 61 | CDT 61 | CDC 61 | CMB 90 | CMB 60 | CVM 95 | CRD 93 | CCR 616 | CCT 97 | CCT 67 | CGM 91 | CGM 61 | CBG 61 | CBP 612 | CFT 610 |
| Type | Island Tube | Island Cube | Tube | Cube | Décor | Décor | Décor | Round Décor | Round Décor | Chimney | Chimney | Décor | Décor | Canopy | Integrated | Standard |
| Colour | X | X | X | X | X | X | X | X | X | X | W/N/X | X | X | W/N/X | W/N/GR | W/N/S |
| Motors (watts) | 250 | 250 | 250 | 250 | 150 | 150 | 230 | 230 | 150 | 230 | 230 | 150 | 150 | 100 | 100 | 120 |
| Max air flow m³/h | 740 | 740 | 550 | 740 | 370 | 370 | 550 | 550 | 450 | 550 | 550 | 450 | 450 | 180 | 240 | 240 |
| Lights | 2x20w | 4x20w | 2x20w | 2x20w | 2x40w | 2x40w | 2x20w | 2x20w | 2x20w | 2x20w | 2x20w | 2x20w | 2x20w | 2x40 | 2x40 | 2x20 |
| | Halogen | Halogen | Halogen | Halogen | Halogen | Halogen | Halogen | Halogen | | Halogen | Halogen | Halogen | Halogen | | | |
| Push button controls | - | - | - | X | X | X | X | X | - | - | - | X | X | - | X | X |
| Touch controls | X | X | X | - | - | - | - | - | - | - | - | - | - | - | - | - |
| Slider control | - | - | - | - | - | - | - | - | X | X | X | - | - | X | - | - |
| Speeds | 4 | 4 | 4 | 3 | 3 | 3 | 3 | 3 | 3 | 3 | 2 | 3 | 3 | 3 | 3 | 3 |
| Washable metal grease filter | 1 | 1 | | | 3 | 3 | 1 | 2 | 2 | 3 | 2 | 1 | 1 | - | - | 1 |
| Charcoal filters | - | - | Opt | Opt | 2 | 2 | 2 | 2 | 2 | 2 | 2 | - | - | 2 | 2 | - |
| Air outlet diameter mm. | 150 | 150 | 150 | 150 | 150 | 150 | 150 | 150 | 150 | 150 | 150 | 150 | 150 | 150 | 123 | 123 |
| Width cm. | 40 | 70 | 40 | 60 | 90 | 60 | 90 | 90 | 60 | 90 | 60 | 90 | 60 | 60 | 60 | 60 |

SPLASHBACK

| Model | PM60X |
|-----------|-------|
| Height cm | 65 |
| Width cm | 60 |
| Depth cm | 10 |

TECHNICAL SPECIFICATIONS / OVENS

| Model | OVENS | | | | | | | | |
|--|-----------------------|-----------------------|-----------------------|-----------------------|----------------|-----------------------|-----------------------|-----------------------|-----------------------|
| | FVH 929XL | FVP 729 | FVP 702/1 | FIR 715 | FFN 403 | FPP 678/1X | FPP 629XL | FPP 609 | FPP407/1 |
| Product description | Multi-function | Multi-function | Multi-function | Multi-function | Fan | Multi-function | Multi-function | Multi-function | Fan |
| Finish | Usee X | Usee X | Usee X | X | X | Pyrolytic X | X | X | W/N/X |
| Main characteristics | | | | | | | | | |
| Programme selector | Electronic programmer | Electronic programmer | Electronic programmer | Electronic programmer | End of cooking | Electronic programmer | Electronic programmer | Electronic programmer | Electronic programmer |
| 24 hour clock | • | • | • | • | - | • | • | • | • |
| Number of glass door panels | 2 | 2 | 2 | 2 | 2 | 4 | 2 | 2 | 2 |
| Grill | • | • | • | • | • | • | • | • | • |
| Thermostat | • | • | • | • | • | • | • | • | • |
| Shelves | 2 | 2 | 2 | 1 | 2 | 2 | 2 | 2 | 2 |
| Roasting tray | 1 | 1 | 1 | 2 | 1 | 1 | 1 | 1 | 1 |
| Self-cleaning panels | Opt. | Opt. | Opt. | Opt | Opt. | - | Opt | Opt | Opt |
| Pyrolytic oven cleaning | - | - | - | - | - | • | - | - | - |
| Technical data | | | | | | | | | |
| Volume (Litres) | 53 | 53 | 53 | 53 | 53 | 53 | 53 | 53 | 53 |
| Maximum temperature °C | 245 | 245 | 245 | 245 | 245 | 280 | 245 | 245 | 245 |
| Energy consumption static function (kWh) | 0.79 | 0.78 | 0.78 | 0.78 | 0.78 | 0.78 | 0.79 | 0.78 | - |
| Energy consumption fan convection(kWh) | 0.71 | 0.71 | 0.71 | 0.71 | 0.71 | 0.71 | 0.78 | 0.71 | 0.71 |
| Maximum absorbed power (kW) | 2.1 | 2.1 | 2.1 | 2.2 | 2.1 | 2.8 | 2.1 | 2.1 | 2.1 |
| Width of cavity mm | 560 | 560 | 560 | 560 | 560 | 560 | 560 | 560 | 560 |
| Height of cavity mm | 580 | 580 | 580 | 580 | 580 | 580 | 580 | 580 | 580 |
| Energy Classification | A-20 | A | A | A | A | A | A | A | A-10 |

| Model | OVENS | | | | | | | | |
|--|----------------|---------------|-----------------------|------------------------------|-----------------------|-----------------------|-------------------|-------------------------|------------|
| | FPP 403/1 | FCL 614/1 | FST 201/1 | FDP 299/2 | FDP 232/2 | TCP 22/2 | OVG 505/2 | MIC 440 TX | MIC 20GDFX |
| Product description | Fan | Multifunction | Static Double oven | Multifunction Double oven | Fan Double oven | Fan | Gas plus grill | Microwave plus grill | Microwave |
| Finish | W/N/X | GH | W/N/X | X/NX | X | X | W/N/X | X | X |
| Main characteristics | | | | | | | | | |
| Main oven | | | | | | | | | |
| Programme selector | End of Cooking | | Minute Minder | Electronic programmer | Electronic programmer | Electronic programmer | Timer | Electronic | Electronic |
| Power levels | - | - | - | - | - | - | - | 5 | 5 |
| 24 hour clock | - | - | - | • | • | • | - | • | • |
| Number of glass door panels | 2 | 2 | 2 | 2 | 2 | 2 | 2 | - | - |
| Grill | • | • | • | • | • | • | • | • | • |
| Turntable | - | - | - | - | - | - | - | • | • |
| Thermostat | - | - | - | - | - | - | - | • | • |
| Shelves | 2 | 2 | 2 | 1 | 1 | 1 | 2 | - | - |
| Roasting tray | 1 | 1 | 1 | 1 | 1 | 1 | 1 | - | - |
| Self-cleaning panels | Opt | - | Opt | - | - | - | - | - | - |
| Second oven | - | - | - | Convection | Convection | Convection | - | - | - |
| Double glass | - | - | - | • | • | • | - | - | - |
| Grill | - | - | - | • | • | • | - | - | - |
| Shelves | - | - | - | 1 | 1 | 1 | - | - | - |
| Roasting tray | - | - | - | 1 | 1 | 1 | - | - | - |
| Technical data | | | | | | | | | |
| Volume (Litres) | 53 | 53 | 53 | 49 + 39 | 54 + 39 | 43 + 39 | 50 | 44 | 20 |
| Maximum temperature °C | 245 | 243 | 245 | 240/260 | 230 | 230 | 240 | 220 | 220 |
| Microwave power rating (W) | - | - | - | - | - | - | - | 900 | 800 |
| Energy consumption static function (kWh) | 0.71 | 0.79 | 0.79 | 0.79 | 0.79 | 0.79 | - | - | - |
| Energy consumption fan convection(kWh) | - | 0.99 | - | 0.99 | 0.99 | 0.97 | - | - | - |
| Maximum absorbed power (kW) | 2.1 | 2.1 | 2.1 | 2.4 | 2.4 | 3.7 | 2.4 | 3.35 | 1.25 |
| Width of cavity mm | 560 | 560 | 560 | 554-564 | 554-564 | 554-564 | 560 | 560 | 560 |
| Height of cavity mm | 580 | 580 | 580 | 875-878 | 875-878 | 705-708 | 580 | 460 | 360 |
| Energy Classification | A-10 | A | A | B/A | B/A | B/A | - | - | - |

TECHNICAL SPECIFICATIONS / HOBS

| Model | GAS HOBS | | | | | | | | | | | | | |
|------------------------------|-------------|-------------|-----------|-------------|-------------|------------|----------|---------------|------------|------------|-----------|----------|------------|-----------|
| | CPG 75 SQGX | CPG 75 SQPX | PG750 SXX | CPG 74 SQGX | PGF750/1SQX | PGF 640/1S | PV 750SX | CPGC 64 SQPGH | PG640/1SXX | CPG 64 SXX | CPG 64 SP | PV 640SN | CLG 64 SGX | CLG 64 SP |
| Product description | 5 Gas | 5 Gas | 5 Gas | 4 Gas | 5 Gas | 4 Gas | 5 Gas | 4 Gas | 4 Gas | 4 Gas | 4 Gas | 4 Gas | 4 Gas | 4 Gas |
| Finish | 75cm | 75cm | 75cm | 75cm | 75cm | 60cm | 75cm | 60cm | 60cm | 60cm | 60cm | 60cm | 60cm | 60cm |
| Main characteristics | X | X | X | X | X | X | X | GH | X | X | B/N/X | X | X | B/N/X |
| Quadruple ring burners | 1 | 1 | - | 1 | 1 | - | 1 | 1 | - | - | - | - | - | - |
| Ultra Rapid burner | - | - | 1 | - | - | 1 | - | - | 1 | 1 | 1 | - | - | - |
| Rapid burner | 2 | 2 | 2 | 1 | 2 | 1 | 2 | 1 | 1 | 1 | 1 | 2 | 1 | 1 |
| Semi-Rapid burner | 1 | 1 | 1 | 1 | 1 | 1 | 2 | 1 | 1 | 1 | 1 | 2 | 2 | 2 |
| Auxiliary burner | 1 | 1 | 1 | 1 | 1 | 1 | - | 1 | 1 | 1 | 1 | - | 1 | 1 |
| One touch ignition | • | • | • | • | • | • | • | • | • | • | • | • | • | • |
| Flame failure device | • | • | • | • | • | • | • | • | • | • | • | • | • | • |
| Cast iron pan supports | • | - | - | • | • | • | - | • | - | - | - | - | • | - |
| Stainless steel pan supports | - | - | • | - | - | - | - | - | • | • | - | - | - | - |
| Enamel pan supports | - | • | - | - | - | - | • | - | - | • | • | - | - | • |
| Technical data | | | | | | | | | | | | | | |
| Power developed burners (kW) | 11.75 | 11.75 | 11.25 | 9.25 | 11.25 | 8.55 | 12 | 9.2 | 8.55 | 8.75 | 8.75 | 8.5 | 7.1 | 7.1 |
| Quadruple burners (kW) | 1x4 | 1x4 | 1x3.5 | 1x4 | 1x3.5 | - | 1x3.5 | 1x4 | - | 1x3.5 | 1x3.5 | - | - | - |
| Ultra rapid burner (kW) | - | - | - | - | - | 1x3.3 | - | - | 1x3.3 | - | - | - | - | - |
| Rapid burners (kW) | 2x2.5 | 2x2.5 | 2x2.5 | 1x2.5 | 2x2.5 | 1x2.5 | 2x2.5 | 1x2.5 | 1x2.5 | 1x2.5 | 1x2.5 | 2x2.5 | 1x2.7 | 1x2.7 |
| Semi-Rapid burners (kW) | 1x1.75 | 1x1.75 | 1x1.75 | 1x1.75 | 1x1.75 | 1x1.75 | 2x1.75 | 1x1.7 | 1x1.75 | 1x1.75 | 1x1.75 | 2x1.75 | 2x1.7 | 2x1.7 |
| Auxiliary burners (kW) | 1x1 | 1x1 | 1x1 | 1x1 | 1x1 | 1x1 | - | 1x1 | 1x1 | 1x1 | 1x1 | - | 1x1 | 1x1 |
| Width of cavity (mm) | 560 | 560 | 560 | 560 | 560 | 560 | 560 | 560 | 560 | 560 | 560 | 560 | 560 | 560 |
| Depth of cavity (mm) | 480 | 480 | 480 | 480 | 480 | 480 | 480 | 480 | 480 | 480 | 480 | 480 | 480 | 480 |
| Width of product (mm) | 745 | 745 | 745 | 750 | 745 | 590 | 747 | 590 | 590 | 590 | 590 | 595 | 595 | 595 |
| Depth of product (mm) | 510 | 510 | 510 | 510 | 510 | 510 | 512 | 510 | 510 | 510 | 510 | 510 | 510 | 510 |
| Height of product (mm) | 35 | 35 | 35 | 30 | 30 | 30 | 50 | 35 | 35 | 35 | 35 | 46 | 37 | 37 |

TECHNICAL SPECIFICATIONS / HOBS

| Model | CERAMIC / INDUCTION / ELECTRIC HOBS | | | | | |
|---------------------------------|--|---|---|---|---|-------------------------------|
| | PVD 742 | CH 642 | CI 640 CBA | CI 640 C | CH 64M | PLE 64 |
| Product description | 75cm Hi-Light Ceramic | 60cm Hi-Light Ceramic | 60cm Induction | 60cm Induction | Hi-Light | Electric |
| Finish | X/N | X/N | N | N | N/X | W/N/X |
| Main characteristics | | | | | | |
| Cooking zones | 4 Hi-Light 1xØ190: 1.8kW 1xØ155x190: 1.8kW 1xØ180x275: 0.9+1.5kW 1xØ155: 1.2kW | 4 Hi-Light 1x155:1.2kW 1x130x220:0.75+1.45kW 2x190:1.8kW | 4 Induction 1x 210:2.0-2.6kW 1x 180:2.0kW 2x 180:1.4kW | 4 Induction 1x 210:2.0kW 1x 180:2.0kW 2x 180:1.4kW | 4 Hi-Light 2x155:1.2kW 1x220:2.3kW 1x190:1.9kW | 4 Hotplates |
| Hotplates | | | | | | 2xØ180:2.0kW 2xØ145: 1.5kW |
| Digital touch controls | • | • | • | • | - | - |
| End of cooking timer | • | • | • | • | • | - |
| Hot hob warning lights | • | • | • | • | • | - |
| Installed electrical power (kW) | 7.6 | 7.0 | 3.0 | 3.0 | 6.5 | 7.0 |
| Width of cavity (mm) | 560 | 560 | 560 | 560 | 560 | 560 |
| Depth of cavity (mm) | 490 | 490 | 490 | 490 | 490 | 480 |
| Width of product (mm) | 745/747 | 590 | 590 | 590 | 590 | 585 |
| Depth of product (mm) | 510/512 | 520 | 520 | 520 | 520 | 500 |
| Height of product (mm) | 50 | 50 | 50 | 50 | 50 | 30 |

TECHNICAL SPECIFICATIONS / DOMINO HOBS

| Model | DOMINO HOBS | | | | | | | | |
|---------------------------------|-------------|------------|-----------------------|-------------|-----------------------|--------------|-----------|----------|---------|
| | CDG 31 SPX | CDG 32 SPX | CDI 32 B | CDH 32 X | CDH 32 C | CDE 32 X | CDVG 30 X | CDB 30 X | CDF 30X |
| Product Description | Gas Hob | Gas Hob | Induction Hob | Ceramic Hob | Ceramic Hob | Electric Hob | Griddle | BBQ | Fryer |
| Finish | X | X | B | X | B | X | X | X | X |
| Cooking Zones / Burners | 1 | 2 | 2 | 2 | 2 | 2 | 1 | 1 | - |
| Flame Failure | • | • | - | - | - | - | - | - | - |
| Controls | One touch | One touch | Digital touch control | Knobs | Digital touch control | Knob | Knob | Knob | Knob |
| Technical data | | | | | | | | | |
| Installed electrical power (kW) | - | - | 4.4 | 3 | 3 | 3 | 1.5 | 2.4 | 2.3 |
| Power developed burners (kW) | 3.8 | 4 | - | - | - | - | - | - | - |
| Width of cavity (mm) | 270 | 270 | 270 | 270 | 270 | 270 | 270 | 270 | 270 |
| Depth of cavity (mm) | 490 | 490 | 490 | 490 | 490 | 490 | 490 | 490 | 490 |
| Width of product (mm) | 290 | 290 | 286 | 290 | 286 | 290 | 290 | 290 | 290 |
| Depth of product (mm) | 510 | 510 | 506 | 510 | 506 | 510 | 510 | 510 | 510 |
| Height of product (mm) | 40 | 40 | 42 | 40 | 42 | 40 | 42 | 40 | 145 |

TECHNICAL SPECIFICATIONS / LAUNDRY

| Model | LAUNDRY | | | | | | | | |
|-----------------------------------|--------------|-----------------|--------------|-----------------|--|------------|----------|---------|----------|
| | CDB 754D/1 | CWB 714D | CDB 264 | CWB 1206 | Technical data | CDB 754D/1 | CWB 714D | CDB 264 | CWB 1206 |
| Product description | Washer dryer | Washing machine | Washer dryer | Washing machine | Energy efficiency class | A | A+ | B | A+ |
| Main characteristics | | | | | Energy consumption wash only kWh | 1.19 | - | 1.14 | 1.02 |
| Washing capacity (kg) | 7 | 7 | 6 | 6 | Energy consumption wash-& dry full load kWh | 5.65 | - | 5.11 | - |
| Drying capacity (kg) | 5 | | 4 | | Wash efficiency class | A | A | A | A |
| Washing/drying programmes | 14/3 | 13 | 18/3 | 15 | Spin efficiency class | A | A | B | B |
| Rapid programme | 14/30/44 | 14/30/44 | 32 | 32 | Water consumption standard-60°C cycle litres | 103*** | 56 | 150*** | 49 |
| Spin speed (r.p.m.) | 1400 | 1400 | 1200 | 1200 | according to regulations | | | | |
| Stainless Steel drum | • | • | • | • | Voltage V | 230 | 230 | 230 | 230 |
| Fuzzy logic | • | • | • | • | Max absorbed power kW | 5.55 | 2.15 | 5.55 | 2.15 |
| Internal steam condensing | • | - | • | - | Fuse rating A | 13 | 13 | 13 | 13 |
| Automatic variable capacity | • | - | • | - | Height mm | 820 | 820 | 820 | 820 |
| Variable spin speed | • | • | • | • | Width mm | 596 | 596 | 596 | 596 |
| Drying time selector | • | • | • | • | Depth mm | 541 | 541 | 541 | 541 |
| Independent temperature regulator | • | • | • | • | Width of cavity mm | 600 | 600 | 600 | 600 |
| Stain blaster button | • | • | - | - | Depth of cavity mm | 570 | 570 | 570 | 570 |
| Allergy care button | • | • | • | • | Height of cavity mm | 825 | 825 | 825 | 825 |
| Super rapid button | - | - | • | • | | | | | |
| Super rinse button | - | - | • | • | | | | | |
| High dry button | • | • | • | • | | | | | |
| Cold fill only | • | • | • | • | | | | | |
| Adjustable feet | • | • | • | • | | | | | |

* relates to dry laundry

** annual estimated consumption for 200 washing cycles (4 people)

*** washing and drying cycle

TECHNICAL SPECIFICATIONS / DISHWASHERS

| Model | DISHWASHERS | | | | | | | | | | |
|---|-------------|-------------|------------|---------|----------|----------------------------------|-------------|-------------|-------------|----------------|-------------|
| | CDI 3530 | CDI 22E10/3 | CDI 1012/3 | CDS 420 | CDI 4545 | Technical data | CDI 3530 | CDI 22E10/3 | CDI 1012/3 | CDS 420 | CDI 4545 |
| Finish | W | W | W | X/N/W | W | N° of IEC place settings | 14 | 12 | 12 | 12 | 9 |
| Main characteristics | | | | | | N° of programmes | 5 | 5 | 5 | 5 | 7 |
| Adjustable upper basket | • | • | • | • | • | Wash temperatures | 75/60/50/45 | 75/65/50/45 | 75/65/50/45 | 75/70/65/50/45 | 70/55/50/45 |
| AISI 304 stainless steel interior | • | • | • | • | • | Water consumption (litres - IEC) | 13 | 10 | 13 | 13 | 13 |
| Double anti-overflow device | - | - | • | - | • | Energy consumption (kW/h IEC) | 1.1 | 1,05 | 1,05 | 1,05 | 0.8 |
| Anti flood device | - | - | - | - | • | Noise power | | | | | |
| Start delay | 3/6/9 | • | - | - | • | dB (A) (re 1 pw) | 50 | 52 | 51 | 52 | 52 |
| Self-cleaning stainless steel microfilter | • | • | • | • | • | Energy efficiency class | A | A | A | A | A |
| Rapid programme (mins) | 32 | 32 | 32 | 32 | 32 | Wash efficiency class | A | A | A | A | A |
| Half load button | • | • | - | - | - | Drying efficiency class | A | A | A | A | A |
| Delicate button | - | - | - | - | - | Width of cavity (mm) | 600 | 600 | 600 | 600 | 450 |
| Economy button | • | - | - | - | • | Depth of cavity (mm) | 570 | 570 | 570 | 570 | 600 |
| Salt consumption light | • | • | - | • | • | Height of cavity (mm) | 820÷885 | 820÷885 | 820÷885 | 820÷885 | 820÷885 |
| Balanced door | • | • | • | • | • | | | | | | |
| Height adjustable feet | • | • | • | • | • | | | | | | |